



सत्यमेव जयते

GOVERNMENT OF INDIA
MINISTRY OF RAILWAYS
(Railway Board)

INDIAN RAILWAY STANDARD
SPECIFICATION FOR FABRICATION AND
ERECTION OF STEEL GIRDER BRIDGES AND
LOCOMOTIVE TURN-TABLES
(FABRICATION SPECIFICATION)

SERIAL NO. B1-2001

ADOPTED -1934

LAST REVISION - 2001

REPRINTED - 2008

(INCORPORATING A & C SLIP UPTO 4)

ISSUED BY

RESEARCH DESIGNS AND STANDARDS ORGANISATION
LUCKNOW - 226011

FOREWORD

1. IRS Specification for Fabrication and Erection of Steel Girder Bridges and Locomotive Turn-table (B1) was adopted in 1934. The Specification was subsequently revised in 1936, 1947, 1962 & 1979. The need for its revision was examined in 69th BSC vide item No. 832. On the recommendations of 69th BSC, Railway Board vide letter No. 98/CE-I/BR-III/13 dated 28-7-98 ordered that revision of IRS Specification B1-79 should be taken up by a Sub-Committee.
2. The Sub-Committee consisting of Director/B&S/RDSO, Dy. Director/M&C/RDSO, CWM/Manmad, CWM/Sabarmati and Assistant Professor (Bridges) IRICEN, Pune have prepared revised draft for IRS Specification for Fabrication and Erection of Steel Girder Bridges and Locomotive Turn-tables. The following officers represented Sub-Committee on revision.

Shri S.S.Gupta	Director/B&S/SB-II/RDSO, Lucknow
Shri M.B.Vijay	Director/B&S/Inspection/RDSO, Lucknow
Shri B.S.Chittoria	CWM/C.Rly./Manmad
Shri M.K.Gupta	CWM/W.Rly./Sabarmati
Shri S.K.Ojha	Dy. Director/M&C/RDSO, Lucknow
Shri N.L.Nadagouda	AP/Bridges, IRICEN, Pune

Shri S.K.Chaturvedi, ADE/B&S/RDSO and Shri T.Chaki, ARO/Met/RDSO assisted the sub-Committee in drafting and finalization of this Specification.
3. The revised draft submitted by Sub-Committee was discussed in extra-Ordinary Meeting of BSC held in February, 2000 at Pune. Railway Board's approval has been communicated vide letter No. 2000/CE-I/Seminar/1 dated 11-09-2000.
4. The following significant changes have been made in this Specification:
 - i) Indian Standard Specifications & IRS Specifications referred to have been updated. RDSO's specifications have been added.
 - ii) Provisions for use of steel in fabrication of steel girder bridges have been updated in present context.
 - iii) Flame cutting by mechanically controlled torches has been incorporated to increase production as well as to minimize lateral distortion, which used to be there due to single torch.
 - iv) Different records of fabrication to be maintained by fabrications have been incorporated with their proforma.
 - v) Provisions for loading of material have been elaborated for safe and secure transportation.
 - vi) Provisions related to sequence of welding to be followed for fabrication of welded girders have been incorporated.
 - vii) Provision to ensure that the steel sections to be used in fabrication of girders conforms to relevant specification has been incorporated.
 - viii) Specification has been suggested with an abbreviated title "Fabrication Specification".

5. After revision of "Fabrication Specification" in 2001, four A&C Slips have been issued and now they have been incorporated in the Re-printed version of "Fabrication Specification".

CONTENTS

	Page
1. <i>Definitions</i>	3
2. <i>Responsibility for Completeness</i>	4
3. <i>Sub-letting of Work</i>	4
4. <i>Stacking Materials</i>	4
5. <i>Imported Material</i>	5
6. <i>Leading to Site</i>	5
7. <i>Lines and Levels</i>	5
8. <i>Steel</i>	5
9. <i>Pins and Expansion Rollers</i>	6
10. <i>Steel Castings</i>	7
11. <i>Bronze Plates</i>	7
12. <i>Maintenance of Records by Fabricators</i>	7
13. <i>Manufacture</i>	7
14. <i>Templates</i>	7
15. <i>Flattening and Straightening</i>	7
16. <i>Planing and Shearing</i>	8
17. <i>Flame Cutting</i>	8
18. <i>Drilling and Sub-punching</i>	8
19. <i>Parts in Contact</i>	9
20. <i>Making of Joints</i>	9
21. <i>Erection and Equipment</i>	10
22. <i>Bearings and Anchorages</i>	11
23. <i>Rivets and Rivetting</i>	11
24. <i>Field Rivets, Bolts, Nuts and Service Accessories</i>	12
25. <i>Smithed Work</i>	13
26. <i>Welding</i>	13
27. <i>Sequence of Welding and Weld Pass</i>	13
28. <i>Bolts, Nuts and Washers</i>	14
29. <i>Connecting Pins</i>	14
30. <i>Pin Holes</i>	14
31. <i>Bearing and Expansion Gear</i>	15
32. <i>Erection in Contractor's Works</i>	15
33. <i>Interchangeability</i>	15

	Page
34. Camber	16
35. Testing	16
36. Check on Tests Made at Contractor's Work	17
37. Analysis	17
38. Inspection - General	17
39. Oiling, Painting and Metallising	17
40. Name Plate	19
41. Erection Mark	19
42. Packing	19
43. Despatch or Shipping Marks	20
44. Loading	20
45. Weight of Steel Work for Payment	21
46. Quantities	21
47. Tracings and Printings	21
48. Rivets and Bolts Lists	21
49. Photographs	21
50. Attestation of Tracings etc	22
51. Inclusive Price	22
52. Deviations from this Specification	22
53. Alterations in Work	22
54. Additional Specification for Locomotive Turn- Tables	22
Appendix-I Records to be Maintained	25
Appendix-II Manufacturing Tolerances	27
Appendix-III Erection of Open Web Girder Span	30
Appendix IV Permissible Deviations for Driven Rivets	31
Appendix-V Proforma for Welding Procedure Specification Sheet	32
Proforma for Welding Procedure Qualification Record	33
Appendix-VI Tolerances & Specification for Knuckle and Roller Bearings	34
Appendix-VII Specification for Metallising with Sprayed Aluminium	35
for Bridge Girders	
Figure 1-4	37

Indian Railway Standard
Specification for Fabrication and Erection of Steel Girder Bridges and
Locomotive Turn-Tables

(FABRICATION SPECIFICATION)

0.1 This Specification is issued under the fixed serial number B1. The final number indicates the year of original adoption as standard or in the case of revision the year of last revision. This Specification was adopted in 1934 and revised in 1936, 1947, 1962, 1979 and 2001.

0.2 This Specification is intended mainly to cover technical provisions relating to fabrication and erection of steel girder bridges and locomotive turn-tables, including supply of the materials through contract or Railway Engineering Workshops.

0.3 This Specification makes reference to the following Indian Standard, Indian Railway standard and RDSO's Specifications:-

0.3.1 Indian Standard (IS) Specifications

- IS: 34 Basic carbonate of lead for paints.
- IS: 51 Zinc chrome for paints.
- IS: 57 Red lead for paints and other purposes.
- IS: 75 Linseed oil, raw and refined.
- IS: 77 Linseed oil, boiled for paints.
- IS: 102 Ready mixed paint, brushing, red lead, non-setting, priming.
- IS: 104 Ready mixed paint, brushing, zinc chrome, priming.

- IS: 123 Ready mixed paint, brushing, finishing, semi gloss, for general purposes to Indian Standard colours.
- IS: 209 Zinc ingot.
- IS: 210 Grey iron casting.
- IS: 549 Split pins.
- IS: 808 Dimensions for hot rolled steel beam, column, channel and angle sections.
- IS: 814 Covered electrodes for manual metal-arc welding of carbon and carbon manganese steel.
- IS: 816 Code of practice for use of metal-arc welding for general construction in mild steel.
- IS: 822 Code of procedure for inspection of welds.
- IS: 887 Animal tallow.
- IS: 958 Temporary corrosion preventive grease, soft film, cold application.
- IS: 962 Code of practice for architectural and building drawings.
- IS: 1030 Carbon steel castings for general engineering purposes.

IS: 1148	Hot rolled steel rivet bars (upto 40mm dia) for structural purposes.	IS: 2004	Carbon steel forging for general engineering purposes.
IS: 1149	High tensile steel rivet bars for structural purpose.	IS: 2016	Plain washers.
IS: 1363	Hexagon head bolts, screws and nuts of product grade C.	IS: 2062	Hot Rolled Low, Medium & High Tensile Structural Steel.
IS: 1364	Hexagon head bolts, screws and nuts of product grade A and B.	IS: 2074	Ready mixed paint, air drying, red oxide-zinc chrome, priming
IS: 1367	Technical supply conditions for threaded fasteners.	IS: 2339	Aluminium paint for general purposes, in dual container
IS: 1458	Railway bronze ingots and castings.	IS: 2590	Primary aluminium ingots for remelting for general engineering purposes.
IS: 1673	Mild steel wire cold heading quality.	IS: 2638	Flat split cotters.
IS: 1730	Steel plates, sheets, strips and flats for structural and general engineering purposes-dimensions.	IS: 3063	Fastners-single coil rectangular section spring washers.
IS: 1745	Petroleum hydrocarbon solvents.	IS: 3502	Steel chequered plates.
IS: 1852	Rolling and cutting tolerances for hot rolled steel products.	IS: 4899	Ferritic and martensitic steel casting for use at low temperatures.
IS: 1875	Carbon steel billets, blooms, slabs and bars for forging.	IS: 5369	General requirements for plain washers and lock washers.
IS: 1929	Hot forged steel rivets for hot closing (12 to 36 mm diameter).	IS: 5372	Taper washers for channels.
IS: 2002	Steel plates for pressure vessels for intermediate and high temperature service including boilers.	IS: 5374	Taper washers for I beams.
		IS: 5666	Etch primer.
		IS: 5905	Sprayed aluminium and zinc coatings on iron and steel.
		IS: 6586	Recommended practice for metal spraying for protection of iron steel.

- IS: 6610 Heavy washers for steel structures.
- IS: 7215 Tolerances for fabrication of steel structures
- IS: 7283 Hot rolled bars for production of bright bars and machined parts for engineering applications.
- IS: 9954 Pictorial surface preparation standards for painting of steel surfaces
- IS: 9595 Metal-arc welding of carbon and carbon manganese steels-recommendations.

0.3.2 IRS Specifications

- R-19 Wheels and axles for carriages and wagons.
- M-3 Class I ,II ,III & IV steel forgings, blooms for forgings and Billets for re-rolling.
- M-28 Classification, testing and approval of metal-arc welding electrodes for use on Indian Railways.
- M-39 Classification, testing and approval of submerged-arc welding wire flux combination.
- M-41 Corrosion resistance steel.
- M-42 High strength low alloy structural steel with enhanced corrosion resistance.
- M-43 High strength low alloy structural steel rivet bars with enhanced corrosion resistance.

- T-12 Flat bottom railway rails.
- P-31 Zinc chromate read-oxide primer.

0.3.3 RDSO's Specifications

- M&C/PCN/102/96 Epoxy zinc phosphate primer.
- M&C/PCN/103/86 Epoxy micaceous iron oxide.
- M&C/PCN/109/88 Polyurethane red oxide.
- M&C/PCN/110/88 Polyurethane aluminium.
- M&C/PCN/111/88 High build Epoxy paint.

0.4 Wherever reference to the standards mentioned in clause 0.3 appears in the Specification, it shall be taken as a reference to the latest version of the standards.

0.5 Any revision or addition or deletion of the provisions of this Specification shall be issued only through the correction slip. No cognizance shall be given to any policy directives issued through other means.

1. Definitions

1.1 Throughout this Specification the following definitions shall be applicable.

1.1.1 „The Purchaser’ means the President of India or his/her representative unless otherwise stated in the case of stores ordered for the Indian Railways.

1.1.2 'The Indentor' means an officer authorized by the Purchaser to order stores.

1.1.3 'The Engineer' means the Consulting Engineer or officer authorised by the Purchaser to act as an Engineer.

1.1.4 'The Inspecting Officer' means the person, firm or department nominated by the Purchaser to inspect the stores on his/her behalf and the Deputies of the Inspecting Officer so nominated.

1.1.5 „The Contractor' means the person, firm, or company with whom the order for the supply/ fabrication/ erection is placed and shall be deemed to include the Contractor's successors (approved by the Purchaser), representatives, heirs, executors and administrators as the case may be unless excluded by terms of the contract.

1.1.6 „The Sub-Contractor' means any person, firm, or company from whom the Contractor may obtain any material or fittings to be used in the supply or manufacture of the stores.

1.1.7 'The Exhibited Drawings' refer to the drawings, which are exhibited or issued for the guidance of persons tendering. The number for each of these drawings is given in the schedule.

1.2 The drawings, supplied by the Contractor, as per which the fabrication is to be executed, when approved by the Engineer will become „Fabrication Drawings'. Also on completion of the work, the Contractor should supply „Completion Drawings' along with alterations if any.

2. Responsibility for Completeness

2.1 The Contractor shall be entirely responsible for the execution of the contract in all respects in accordance with the terms of this Specification and the conditions of contract, notwithstanding any approval which the Engineer/Inspecting Officer may have given to the detailed drawings

prepared by the Contractor or Sub-Contractor for materials or other parts of the work involved in the contract or for tests carried out, either by the Contractor or by the Engineer/Inspecting Officer.

2.2 Any fitting, accessory or apparatus which may not have been mentioned in this Specification, but which are usual or necessary in the execution of such work, are to be provided by the Contractor without extra charge. The whole work must be completed in all details, whether mentioned in this Specification or not, with the exception of such work as has been specified in the Schedule of Requirements to be separately provided for by the Purchaser.

3. Sub-letting of Work

3.1 Before ordering sub-letting of work, the Contractor shall submit the names of the Sub-Contractors proposed for the approval of the Engineer and shall afterwards send the Inspecting Officer a copy of the orders for the sub-letted work.

3.1.1 The Contractor shall be responsible for all the sub-letted work. Such work shall be inspected and verified by the Inspecting Officer.

4. Stacking Materials

4.1.1 On receipt of materials at the bridge yard they shall be carefully unloaded examined for defects, checked, sorted and stacked securely on a level bed out of danger from flood or tide and out of contact with water or ground moisture. All material shall be available for inspection by the Engineer or Inspecting Officer.

4.1.2 Materials shall be verified with the markings shown on the marking plan of part list, which shall be supplied by the manufacturers or the Engineer.

4.1.3 Any material found damaged during transit or while unloading should be stacked separately and damaged portions shall be indicated by paint with distinctive colour. All such materials shall be dealt with under the orders of the Engineer without delay. If any component after receipt at site, has in the opinion of the Engineer or Purchaser, been damaged in transit, such component shall be replaced or repaired to the satisfaction of the Engineer or Purchaser free of cost.

4.1.4 All such damaged material shall be dealt with as per the orders of the Engineer. Badly damaged portions may require replacement. Slightly distorted parts may be straightened by gradual pressure without heat or annealing. Badly distorted or broken parts must be dealt with as the case demands and as directed by the Engineer.

4.1.5 Where the work has been passed in the manufacturer's works as strictly interchangeable, all members bearing the same marks can be stacked together without reference to any particular span.

4.1.6 The Contractor shall unload the material promptly on delivery; otherwise he/she shall be responsible for demurrage charges.

4.1.7 On receipt of rolled steel at workshop or fabrication yard they shall be carefully unloaded and stacked properly to avoid bending, twisting, corrosion etc.

5. Imported Material

5.1 In case of work fabricated in India, where any material or component is imported, such material or component will be inspected, if desired by the Contractor, Purchaser or Inspecting Officer, and passed in the country of origin before despatch to India. In such cases the Contractor shall submit to the Inspecting Officer details on prescribed form in quadruplicate of the materials or components to be inspected

together with the requisite number of copies of all necessary documents, to enable inspection to be carried out prior to despatch. The cost of such inspection and supervision of tests in connection therewith will be borne by the Purchaser, the Sub-Contractor providing free of charge all material, labour and appliances for carrying out tests made in his/her works and any material which may be required for independent tests and analysis.

6. Leading to Site

6.1 Care must be taken by the Contractor to see that the parts at site are available in proper sequence.

7. Lines and Levels

7.1 All lines and levels should be given by the Engineer and all stakes and marks so given shall be carefully preserved by the Contractor who shall give all necessary assistance and facilities to establish or check the lines and levels and to measure the work.

8. Steel

8.1 IS:2062, Quality "A" Grade Designation E250 (Fe 410 W) as rolled semi-killed or killed shall be used for foot-over bridges and other structures subjected to non-critical loading.

8.2 IS:2062, Quality "B" Grade Designation E250 (Fe 410 W) fully killed and normalized/controlled cooled, where service temperature does not fall below 0⁰C, shall be used for welded/riveted girders subjected to Railway loading. Plates less than 12mm thick need not be normalized/controlled-cooled.

8.3 IS:2062, Quality "C" Grade Designation E250 (Fe 410 W) fully killed and normalized/controlled cooled, ensuring impact properties at (-) 20⁰ C or

(-) 40⁰ C shall be used for sub-zero temperature areas for welded/riveted girders subjected to Railway loading. Plates less than 12mm thick need not be normalized/controlled-cooled.

NOTE: Rolled Sections like angles, channels, I-sections etc., conforming to IS:2062 **Quality ,A'** may be used in structures till such time rolled sections conforming to IS: 2062 **Quality B/C** are not available in the market.

8.4 High tensile steel shall comply in all respects with the requirement of IS:2062-2006 Grade Designation E 410 (Fe 540) or E 450 (Fe 570) Quality D (both copper bearing quality) according to the welded or riveted work respectively.

8.5 For superior and enhanced corrosion resistance for sections, plates and bars for welded, rivetted or bolted construction, the material shall comply with the requirement of IRS:M-42, Gr I or Gr.II for rivetted/bolted or welded work respectively.

8.6 Steel, which is to be cold pressed, shall comply with the requirements of IS:2002.

8.7 Steel for bolts shall conform to property class 4.6 or 6.6 as specified in IS:1367 accordingly, as the structural steel specification is for mild steel or high tensile steel.

8.8 Steel for drifts shall be in accordance with IS:1875 for forged quality steel or IS:7283 for hot rolled bars.

8.9 Steel for rivets shall comply with the requirement of IS:1148 for hot rolled rivet bars for general structural purposes and IS:1149 for high tensile steel rivet bars for high strength structural purposes. For high

strength low alloy structural steel rivet bars with enhanced corrosion resistance for use in bridges, steel shall comply with the requirement of IRS:M-43.

8.10 The dimensions of all rolled sections must agree with the contract drawings or as agreed to between the Purchaser and the Contractor.

8.11 The rolling and cutting tolerances shall be in accordance with IS:1852 or as agreed to between the Purchaser and the Contractor if closer tolerances are desired they shall be shown in the drawing.

8.12 All the steel sections used in the fabrication must have mill test certificate clearly indicating the specification to which the steel conforms and whether steel is killed and normalized. All the cast mark numbers/ heat mark numbers, shall be recorded along-with the number of plates in a register as soon as the plates are received in the workshop. Whenever the steel is received without any test certificate, a sample test piece from plate of each cast mark number is to be cut and sent for testing. Only when it is established that the plates are of required specification, these shall be processed for cutting.

8.13 Use of steel of any quality other than those mentioned above would require the prior approval of the Engineer.

9. Pins and Expansion Rollers

9.1 Pins and Expansion Rollers shall be made from steel conforming to IS:2004 (Class 3 steel).

9.2 Expansion rollers may, alternatively be turned from approved carriage and wagon axles. Only axles manufactured after 1931 shall be used for the manufacture of rollers. USFD test shall be conducted to ensure freeness from internal

flaw. Test pieces shall be left as an integral part of the roller with the stamp of the supplier on it so that the Accepting Authority can cut-off the test pieces and check if required.

10. Steel Castings

10.1 Steel casting shall comply with IS:1030 for normal temperature zone and to IS:4899 for use at low temperature zone.

11. Bronze Plates

11.1 Bronze plates shall be of phosphor bronze complying with IS:1458 Class I.

12. Maintenance of Records by Fabricators

12.1 The records of fabrication shall be maintained in the registers as per the formats given in the **Appendix I**.

13. Manufacture

13.1 The whole work shall be representative of the highest class of workmanship. The greatest accuracy shall be observed in the design, manufacture and erection of every part of the work to ensure that all parts will fit accurately together on erection. For manufacture of the components of all spans to be made strictly interchangeable as specified in clause 33, approved set of same jigs and assembly fixtures shall be used. The tolerances in manufacture shall be in accordance with as shown in **Appendix II**. The Contractor shall state which of the following alternative methods of manufacture he/she intends to adopt.

- i) The whole of work to be erected complete and pieces marked to place.

- ii) All spans to be made strictly interchangeable as specified in clause 33.

13.2 The Contractor shall maintain a master steel tape of approved make for which he/she has obtained a certificate of accuracy from any National Test House or Government recognised institutions competent to do so.

14. Templates

14.1 The templates through out the work shall be of steel. The template shall be used for marking of cutting material and as well as profile machining for girders of railway loading. Templates shall be used for marking of drilling holes in steel structures other than girder of Railway loadings. In case where actual materials from a bridge have been used as templates for drilling similar pieces the Inspecting Officer will decide whether they are fit to be used as part of the finished structure.

15. Flattening and Straightening

15.1 All steel materials, plates, bars and structural's shall have straight edges, flat surfaces and be free from twist. If necessary, they shall be cold straightened or flattened by pressure before being worked or assembled unless they are required to be of curvilinear form. Pressure applied for straightening or flattening shall be such as it would not injure the material and adjacent surfaces or edges shall be in close contact or at uniform distance throughout.

15.2 Flattening and straightening under hot condition shall not be carried out unless authorized and approved by the Inspecting Officer.

16. Planing and Shearing

16.1 Except where otherwise indicated, cutting of all plates and sections shall be affected by shearing or sawing. All edges shall be clean, reasonably square and true. Wherever possible the edges shall be cut in a shearing machine, which will take the whole length of the plate in one cut.

16.2 Should the inspection find it necessary, the cut edges shall be ground afterwards.

16.3 Planing or machining of the edges or surface shall be carried out when so specified in the contract drawings or where specifically ordered by the Engineer. Where machining is specified, the plates or all sections shall be cut in the first instance to such a size so as to permit not less than 3mm of metal being removed from each sheared edge or end, in the case of plates or sections of 12mm or less in thickness and not less than 6mm of metal being removed in the case of plates and sections exceeding 12mm in thickness.

16.4 The butting ends of all booms and struts where spliced shall be faced in an end milling machine after members have been completely fabricated. In the case of compression members the face shall be machined so that the faces are at right angle to the axis of the members and the joint when made, will be in close contact throughout. At the discretion of the Inspecting Officer, a tolerance of 0.4mm may be permitted at isolated places on the butting line.

17. Flame Cutting

17.1 Flame cutting by mechanically controlled torch/torches shall be accepted both in the case of mild steel and high tensile steelwork. Provided the edge as given by the torch is reasonably clean and

straight, plates may be cut to shape and beams and other sections cut to length with a gas cutting torch, preferably oxyacetylene gas should be used.

17.2 All flame cut edges shall be ground to obtain reasonably clean square and true edges. Draglines produced by flame cut should be removed.

17.3 Unless machining has been specifically provided for, special care is to be taken to ensure that ends of all plates and members are reasonably in close contact and the faces are at right angles to the axis of the members and joints, when made, are also reasonably in close contact.

17.4 Use of multi-head flame cutting machine having multiple oxy acetylene torches is desirable for higher productivity and reducing the distortion due to cutting operation. Plasma-arc cutting method can also be employed. This process offers less heat input causing less distortion.

18. Drilling and Sub-punching

18.1 All holes shall be drilled but the Contractor may, if he/she so prefers sub-punch them to a diameter 6mm less than that of finished holes, e.g. a punched hole which is to be drilled out to 25mm in diameter shall not exceed 19mm in diameter at the die end. When the rivet holes are to be sub-punched, they shall be marked with a centre punch and made with a nipple punch or preferably, shall be punched in a machine in which the position of the hole is automatically regulated. The punching shall be so accurate that when the work has been put together before drilling, a gauge 1.5mm less in diameter than the size of the punched holes can be passed easily through all the holes. Holes for countersunk heads of rivets, bolts or screws shall be drilled to the correct profile so as to keep the heads flush with the

surface Holes for countersunk heads of rivets, bolts or screws shall be drilled to the correct profile so as to keep the heads flush with the surface

18.2 No sub-punching shall be allowed in the main truss members of open-web girders.

18.3 Holes for turned bolts, should be 1mm under drilled in shop and should be reamed at site to suit the diameter of turned bolt.

18.4 Where the number of thicknesses to be rivetted exceeds three or the total thickness is 90mm or more, the rivet holes, unless they have been drilled through steel-bushed jigs, shall be drilled out in place 3mm all round, after assembling. In such cases the work shall be thoroughly bolted together.

18.5 The steel bushes shall be case hardened by an approved process and checked for diameter after the heat-treatment. The bores of bushes shall initially have a tolerance of $-0\text{mm}, 0.1\text{mm}$. The tolerance shall be checked from time to time and when the bores exceed a tolerance of, $-0\text{mm}, +0.4\text{mm}$, the bushes shall be rejected. For this purpose, go and no-go gauges are to be used. Tolerances for checking jigs from master plates shall be $+0\text{mm}-0.13\text{mm}$.

18.6 The work shall be taken apart after drilling and all burrs left by the drill and the sharp edges of all the rivet holes completely removed.

19. Parts in Contact

19.1 All steel work intended to be rivetted or bolted together shall be in contact over the whole surface.

19.2 Drifts as shown in **Fig. 2** may be used for drawing light members into position

but their use on heavy members should be restricted to securing them in their correct positions. In no case, shall drifting be allowed to such an extent that holes are distorted.

19.3 Drifting to enlarge unfaired holes is prohibited. The holes that will have to be enlarged to admit rivets should be reamed provided the Engineer permits such reaming after satisfying himself about the extent of inaccuracy and the effect of reaming on the soundness of the structure. The Purchaser retains the right to reject all steel work if the holes are not properly matched.

20. Making of Joints

20.1 Cleaning of permanent contact surfaces:- Surfaces which will have permanent contact shall be removed of paints and mill scale down to bare metal, clean and dried and immediately a coating of zinc chrome red oxide priming to IS:2074 shall be applied. Care shall be taken to see that all burrs are removed and no surface defects exist before the parts are assembled.

20.2 Bolting and Drifting:- Only barrel drifts as per **Fig. 2** shall be used in erection. They may be used for drawing light members into position; but their use on heavy members shall be restricted to securing them in their correct position. Any apparent error in shop work, which prevents the assembling and fitting up of the parts by the proper use of these drifts, shall be investigated immediately. As all work is rigidly inspected in the manufacturers work before despatch, these difficulties should not arise and the cause should be first be sought in the use of incorrect components or the transposition of a correct part. It is usually important that parts should be correctly handled. Should error still persist, the matter shall be

immediately reported to the Engineer who will decide what action is to be taken. No reaming shall be undertaken without the written authority of the Engineer, except for the under drilled holes meant for turned bolts. If approved, the Contractor shall supply, at his/her own expense, any special rivets that maybe required. Copies of all correspondence relative to the recourse to reaming and the use of over-size rivets shall invariably be sent by the Engineer for information to the inspectorate concerned.

20.3 Joints shall normally be made by filling not less than 50% of the holes with service bolts and barrel drifts in the ratio of four to one. The service bolts are to be fully tightened up as soon as the joint is assembled.

20.4 Special methods of erection other than described in **Appendix III**. In cases where the joints have to withstand stresses arising from special method of erection, provision is to be made to take the whole stress that will or may occur. Cylindrical drifts and turned bolts shall be used to withstand such stresses and no reliance is to be placed on the service bolts for this purpose. Upto maximum of 40% of the holes of each member of the joint are to be filled with drifts and balance of strength required is to be attained with turn bolts. The position and number of the drifts and bolts will be intimated by the Engineer. The condition of clause 20.1 must be observed and the bolt fully tightened up as soon as the joint is made.

20.5 Where the manufacturing of girders has been done in accordance with clause 33 relating to steel girder bridges, the erection shall be done in accordance with **Appendix III**. However, if the Contractor desires to adopt any other method of erection, he/she shall submit the scheme and obtain the approval of the Engineer. It shall be ensured

that when in position, the girder has the camber as per drawing.

20.6 Emergency Jointing:- In the event of an emergency arising such as the staging is in danger of being carried away by floods before the rivetting can be completed, the joints shall be made secure by filling 40% of the holes with cylindrical drifts and equal number with service bolts fully tightened .

21. Erection and Equipment

21.1 The Contractor shall provide at his/her own cost all tools, machinery, equipment and erection material necessary for the expeditious execution of the work and shall erect the structural steel and iron work, in every respect as covered by the contract and in accordance with the drawings and specifications.

21.2 If any labour, material, plant staging haulage and storage facilities are to be provided by the Purchaser, details of such items and the conditions under which these are to be supplied shall be clearly specified in the contract agreements. In the absence of any such provisions in the agreement, the Contractor shall make his/her own arrangement for such items.

21.3 Before starting the work, the Contractor shall advise the Engineer fully as to the method he/she proposes to follow and the amount and character of equipment he/she proposes to use, which shall be subjected to the approval of the Engineer. The approval of the Engineer shall not be considered as relieving the Contractor of the responsibility for the safety of his/her method or equipment or from carrying the work in full accordance with the drawings and specifications.

21.4 All temporary work shall be properly designed and substantially constructed for the loads, which it will be called upon to

support. Adequate allowance and provision of a lateral forces and wind loads shall be made according to local conditions and ensure that support shall not settle during erection.

21.5 Careful and periodical inspection of plants shall be made by the Contractor to ensure that all tackle, ropes, chains and other important lifting gear and machinery are in good order and fit for service and well upto the capacity for which they are required.

21.6 When chains are used for lashing, care must be taken to protect the edges of members to avoid the marking and distortion otherwise caused.

21.7 Span erected upon staging shall be supported upon suitable blocks, which shall ensure that the girders shall be at the correct elevation and alignment when completed. If other methods of erection be adopted where staging in situ is not employed, special means shall be used to ensure this.

21.8 The method used for lifting and slinging flexible members shall be brought to the notice of the Engineer and shall be subject to his/her approval.

21.9 Temporary bracing shall be provided to take care of stresses from erection equipment or other loads carried during erection.

22. Bearings and Anchorages

22.1 Bed plates shall be set to required level and fixed accurately in position by giving full and even bearing by setting them on a layer of cement sand and cast iron chips as approved and directed by the Engineer.

22.2 The Contractor shall drill the holes where necessary and set the anchor bolts.

The bolts shall be set accurately and fixed with cement grout or any other grouting material as approved by the Engineer completely filling the holes.

23. Rivets and Rivetting

23.1 The dimensions on the drawings referred to the diameters of the rivet holes and their finished rivets. The rivet holes shall be 1.5 mm greater than the diameter of the rivet bars used. The rivets shall be made to IS:1929. The shanks of the undriven rivets shall be made of a length sufficient to fill the holes thoroughly and form the head. The clearance i.e. the difference in diameter between the rivets measured under head before being heated and the rivet hole shall not be less than 0.75mm. Before riveting is commenced, all works shall be properly bolted so that the sections rivetted are in close contact throughout. Rivets shall completely fill the holes and shall be machine driven by means of pressure or percussion rivetters of approved design.

23.2 All rivets shall be properly heated to straw heat for the full length of the shank, firmly backed and closed. The head of the rivet, particularly in long rivets, shall be heated more than the point and in no case shall the point be heated, more than the head. Sparking or burnt rivets shall not be used. Where it is impossible to back up by normal method of holding up, „double gunning’ may be resorted to. Alternatively pneumatic holding device may be used.

23.3 Gauges for rivet dimensions and contours shall be provided by the Contractor for the use of the Inspecting Officer.

23.4 Rivets when driven shall completely fill the holes, have the heads concentric with the shanks and shall be in full contact with the surface. Driven rivets when struck

sharply on the head with the 110-gm. rivet testing hammer, shall be free from movement or vibration.

23.5 While rivetting built-up members great care should be exercised to ensure that the set of holes for field rivets in each flange of the built-up member, is aligned dead-square in relation to that in the other flange and not „aberrated’. Use of assembly fixtures shall be made to ensure this.

23.6 All loose and burnt rivets and rivets with cracks badly formed, eccentric or deficient heads shall be cut out and replaced. Permissible deviation of driven rivets shall be as per **Appendix IV**. Rivets shall also be cut out when required for the examination of the work. Actual method of cutting out shall be approved by the Engineer. Recupping and caulking shall in no circumstances be resorted to.

23.7 Rivetting shall not be started until such time as the Engineer has personally satisfied himself that the alignment of the girders is correct, the verticals plumb laterally, the camber according to that shown on the camber diagram with camber jacks screwed tight, all the joints and cover plates well up, service bolts tight and field rivet holes coinciding. Special care should be taken that service bolts are frequently re-tightened as the rivetting proceeds.

23.8 All field rivets shall be tested as directed by the Engineer.

23.9 Where practicable all rivetting shall be done by pneumatic or hydraulic rivetting machine. The working pressure to be employed when using pneumatic or hydraulic tools shall be approved by the Engineer. Hand rivetting shall only be done when sanctioned by the Engineer. In such cases, means shall be adopted to ensure the rivets being used in their entire length so as to fill the rivet holes completely, the snap

being used only to give the correct form of head.

23.10 When all the rivets of joints have been finally passed, they shall be painted as under.

- a) one coat of ready mixed zinc chrome primer to IS:104 followed by one coat of ready mixed paint red oxide zinc chrome primer to IS:2074
- b) Finishing coat as per clause 39

24. Field Rivets, Bolts, Nuts and Service Accessories

24.1 The work is to include supply of all units, bolts, nuts, washers etc. required to complete erection at site with an allowance for wastage etc. of 12.5% of the net number of field rivets, bolts and washers required subject to a minimum number of five in each item.

24.2 The Contractor shall be responsible for supplying site rivets of approved length. The length of such rivets shall be verified by snapping a few rivets of each length in the presence of the Inspecting Officer. In the case of rivets with long grips (with grip exceeding 6 times the diameter) specimen rivets on the test piece shall be cut to see if the holes are totally filled even though the rivets are tight under the usual hammer tests.

24.3 Black hexagonal bolts (Service bolts) with nuts and ordinary platter’s washers and drifts for use in the erection of the work shall also be supplied at 60% (45% bolts and 15% drifts) of the number of field rivets per span in each size (this includes wastage). The Purchaser may however, specify a reduction in the quantities of service bolts etc. if more than one span of each type is ordered.

25. Smithed Work

25.1 All joggles shall be performed by pressure. Craned sections or knees can be formed by forging or by gas cutting and welding by any approved electric arc process. Any bending, forging, cutting or welding shall be carried out in such a manner as not to impair the strength in the metal. Forging shall be annealed as indicated in the drawing.

25.2 If drop forging through dies is resorted to, excessive forging in one operation shall be avoided. Where necessary, a series of intermediate stage dies shall be manufactured and used.

26. Welding

26.1 Welded construction work shall be carried out generally in accordance with the provisions of Indian Railway Standard Welded Bridge Code and subject to further specifications given in the following paragraphs.

26.2 All welds should be done by submerged-arc welding process either fully automatic or semi-automatic. Carbon di oxide welding or manual metal-arc welding may be done only for welds of very short runs or of minor importance or where access of the locations of weld do not permit automatic or semi-automatic welding.

26.3 Except for special types of edge preparation, such as single and double „U’ single and double „J’ the fusion edges of all the plates which are to be joined by welding may be prepared by using mechanically controlled automatic flame cutting equipment and then ground to a smooth finish. Special edge preparation should be made by machining or gouging.

26.4 Welding procedures:- The welding procedure shall be such as to avoid

distortion and minimise residual shrinkage stresses. Properly designed jigs should be used for assembly. The welding techniques and sequence, quality, size of electrodes, voltage and current required shall be as prescribed by manufacturers of the material and welding equipment. The Contractor should submit full details of welding procedure in proforma given at **Appendix V**.

26.5 Site welding should not be undertaken except in special circumstances with the approval of the Chief Bridge Engineer. Site welding should be confined to connections having low stresses, secondary members, bracings etc.

26.6 Manual metal arc welding may be done taking adequate precautions as per IS:9595 and under strict supervision.

27. Sequence of Welding and Weld Pass

27.1 For fabrication of welded composite girders, channel shear connectors shall be welded on top flange plate prior to assembly of I-section. This facilitates correction of any distortion of flange plate developed during the welding of channel shear connectors.

27.2 In making a typical I-section four fillet welds are to be made. The welding sequence to be followed is indicated by number 1 to 4 as shown in the **Fig. 3**.

27.3 Whenever a square butt weld in a 10 or 12mm thick plate is required to be made, the sequence to be adopted is shown in **Fig. 3**.

28. Bolts, Nuts and Washers

28.1 Bolts, Nuts and Washers shall be in accordance with the following specifications:-

- (i) Black hexagonal bolts to IS:6639 and Nuts to IS:1363.
- (ii) Precision and turned bolts with nuts and hexagonal screws to IS:1364.
- (iii) Plain washers to IS:2016 and IS:5369.
- (iv) Spring washers - IS:3063.
- (v) Taper washers - IS:5372 and IS:5374.

28.2 Manufacture, workmanship, Marking, Packing etc. for Bolts and Nuts shall comply with the requirements of IS:1367.

28.3 Where the head and nuts bear on timber, square washers having the length of each side not less than three diameters of the bolt and the thickness not less than one quarter of the diameter shall be provided. Steel, wrought iron or malleable cast iron taper washers shall also be provided for all heads and nuts bearing on bevelled surfaces.

28.4 For black bolts a clearance (difference in diameter) of 1.5mm for all sizes of bolts shall be allowed.

28.5 Where turned bolts are required they shall be carefully turned and shall be parallel throughout the barrel. Holes for turned bolts should be 1mm underdrilled in shop and should be reamed at site to suit the diameter of the turned bolts.

28.6 The following limits of tolerances, shall be permitted upon the diameter of the shank of turned bolts and of the holes which they are to fit:

Limit of tolerance	Shank of bolt(mm)	Hole(mm)
High	0.000	+0.125
Low	- 0.125	0.000

28.7 The shank of each turned bolt shall be of such a length that it is in full contact with the work, throughout, the screwed portion being made at least 1.5mm less in diameter than the shank or to suit the next smaller size of screw thread. The shank portion shall be joined to the threaded portion by a 45° chamfer within the thickness of the washer. Washers with perfectly flat faces should be provided with all turned bolts.

28.8 The washers under the nut shall have a hole of 1.5mm larger in diameter than the shank of the bolt and shall have a thickness of not less than 6mm so that the nut, when screwed up, shall not bear on the shoulder of the bolt.

29. Connecting Pins

29.1 All connecting pins shall be finished accurately to gauge and parallel throughout, straight and with smooth surface entirely free from flaws and of sufficient length to ensure that all parts connected thereby shall have a full bearing on the pin. They shall be turned to a smaller diameter at the end for the thread and driven to place with a pilot nut, where necessary to preserve the thread.

30. Pin Holes

30.1 Pinholes shall be bored smooth straight and true to gauge and at right angles to the axis of the member. Boring shall only be done after the member has been rivetted up and the diameter of the pin shall not be less than that of the hole by more than 0.5mm.

31. Bearing and Expansion Gear

31.1 All steel bed and bearing plates or plates over saddle castings, shall be made perfectly level and all rivet heads on their bearing surfaces shall countersunk and dressed flush.

31.2 The saddles, knuckle-bearers and roller bed-plates shall be planed on all bearing surfaces and elsewhere as indicated on the Contract Drawings and all bolt-holes shall be drilled. The bottom edge of ribs should be machined and welded to the bottom slabs after which the top edges of the ribs should be machined as a whole and the top plate welded. Subsequently the top and bottom surfaces should be machined to the specified tolerances as given in **Appendix VI**. Generally in connection with the bearing gear all meeting surfaces including the sides of the roller frames, shall be machined, all bolts except anchor bolts turned and fitted, all washers faced, the rollers knuckles and pins polished to smooth surface and the whole finished in the style of first class machined work.

31.3 Tolerances shall be as specified in **Appendix VI** and shall be shown on the drawings.

32. Erection in Contractor's Works

32.1 The work shall be temporarily erected complete at the Contractor's Works for inspection by the Inspecting Officer, with the exception of such rivetting as has to be done at site, so that accuracy of fit and perfection of workmanship may be assured. The work shall be put together with sufficient numbers of parallel drifts or turned bolts or both to bring the pieces into place. When so erected all holes left to be filled at site shall be so fair that a parallel gauge turned to a diameter 0.8mm less than that of the hole, of a length equal to the depth of the hole, can be passed through them without difficulty.

No drift shall be used anywhere in the work larger in any part than the hole in which it is to be driven. Holes for turned bolts, which have been 1 mm underdrilled in shop, should be reamed at site by the erecting agency.

33. Interchangeability

33.1 Every span is to be temporarily erected complete in Contractor's works adopting the method of giving camber as explained in clause 34 and all parts as marked to their place, unless the whole of the work is made completely interchangeable by the use of steel jigs and hard steel bushes controlled by master gauges, in which case the first span must be completely erected to test the accuracy of the templates. Further spans or part span assemblies built from parts selected at random by the Inspecting Officer shall be erected from time to time to check the accuracy of the work as the Inspecting Officer may require.

33.2 If the work is considered interchangeable by the Inspecting Officer a simplified scheme of marking will be permitted, i.e. all pieces which are identical shall bear one distinguishing mark irrespective of the span to which they belong. Should the interchangeability not to the satisfaction of the Inspecting Officer, the whole of the spans must be erected complete and all parts marked to their place without additional charge. The tenderers must state in their tenders whether they intend to adopt complete interchangeability or not.

33.3 Under special arrangement with the Purchaser, it shall be permissible for approved portions of the work to be despatched before complete erection of the first span, provided the Contractor satisfies the Inspecting Officer that such portions of the work are strictly interchangeable and

will assemble correctly and accurately in the complete structure.

34. Camber

34.1 In order to ensure that the fabrication and erection of main girders shall be such as to eliminate secondary stresses in the loaded span, the nominal length (i.e. the lengths which will give no camber) of member shall be increased or decreased by the amount shown on the camber diagram supplied by the Purchaser.

34.2 For setting of the angles of intersection of the chords and web members and also for templating the gusset, full size of panels with nominal lengths of the members, shall be used. Similarly, the machining of all chords butts shall be to suit the nominal outline as defined in clause No. 34.1.

34.3 The procedure for erecting the span at Contractor's work shall be as specified. The site rivetting holes shall be rivetted or bolted and drifted as specified in **Appendix III**.

34.4 When supported on blocks or stagings, the girders shall be erected to the camber specified in the fabrication drawings according to which the girders have been manufactured. A camber diagram indicating the relevant height of each panel point when erected on blocks at the manufacturing works shall be supplied by the Engineer.

34.5 The cambering of the main girders alongwith pre-stressing, when all panel points are supported on the blocks or stagings, shall be carried out in accordance with Appendix 'A' of Steel Bridge Code.

34.6 Special methods of erection will require special erection drawings approved by the Engineer, which must not be deviated from.

34.7 In the case where the girders are erected on yielding supports such as a service span, due allowance shall be made for the anticipated yield when the camber blocks are set out.

34.8 Frequent checks shall be made of the camber of girders during erection and care taken to see that the camber as per drawing is obtained when the girder is completely assembled. When span is supported on ends and intermediate supports are removed the dead load camber shall be recorded and entered in bridge register. This will provide the reference to compare the camber checked during technical inspection to ascertain the loss of camber.

35. Testing

35.1 The Inspecting Officer shall be empowered, at his/her discretion to make or have made under the supervision, any of the tests specified in the specifications mentioned herein in addition to such other tests as he/she may consider necessary, at any time upto the completion of the contract and to such an extent as he/she may think necessary to determine the quality of all materials used therein. In doing so, he/she shall be at liberty under any reasonable procedure, he/she may think fit to select, identify, have cut-off and take possession of test pieces from the material either before, during or after its being worked up into the finished product.

35.2 He shall also be empowered to call for a duly authenticated series of mechanical tests to be obtained from the maker for this materials used in the work and to accept the same in lieu of other tests to the extent he/she deems fit. The Contractor shall supply the material required for the test pieces and shall also prepare the test pieces necessary.

35.3 The test shall be carried out by the Contractor, for which Contractor shall provide all facilities including supply of labour and plant. Inspecting officer may at his/her discretion direct the Contractor to despatch such tests pieces as he/she may require to the National Test House or elsewhere as he/she may think fit for such testing purposes.

36. Check on Tests Made at Contractor's Work

36.1 The Inspecting Officer may at his/her discretion, check test results obtained at Contractor's work by independent tests at National Test House.

36.2 The Inspecting Officer shall at all times be empowered to examine and check the working of the Contractor's plant before and after using it. Should the Contractor's plant be found, in the Inspecting Officer's opinion, unreliable, he/she is empowered to cancel any tests already carried out in this contract and have these tests carried out at any National Test House or elsewhere, as he/she may think fit.

37. Analysis

37.1 The Contractor shall supply authenticated copies of analysis of any materials used in the contract when required to do so by the Inspecting Officer who shall be empowered to accept them to the extent he/she thinks fit. In addition to the above samples may, at the Inspecting Officer's discretion be subjected to complete analysis at the National Test House or elsewhere as the Inspecting Officer may determine, the cost of the same to be borne by the Purchaser.

38. Inspection - General

38.1 The Inspecting Officer shall have free access to the works of the Contractor at all

reasonable times and shall be at liberty to inspect the process of manufacture at any such time and to reject in whole or part, any work or material that does not conform to the provisions of this Specification and may order the same to be removed, replaced or altered at the expense of the Contractor. All gauges and templates necessary to satisfy the Inspecting Officer of the complete interchangeability of parts must be supplied by the Contractor free of cost.

39. Oiling, Painting and Metallising

39.1 No part of the work shall be painted or coated, packed or despatched, until it has been finally inspected and approved by the Inspecting Officer. Dry Film Thickness shall be measured by elcometer or any other approved method.

39.2 When so specified by the Purchaser, the whole of the work except machined surfaces shall be given protective coating using one of the systems of painting or metallising given in clauses 39.2.1 to 39.2.4. Prior to the application of protective coating, the surface of work shall be carefully prepared removing mill-scale, rust, etc. using wire brushes, sand or grit blasting as stipulated and approved by the Purchaser.

39.2.1 For locations where the girders are subjected to salt spray such as in close vicinity of the sea and/or over creeks etc. the protective coating by metallising with sprayed aluminium as given in the **Appendix VII** followed by painting as per painting schedule given below may be applied:

- (i) One coat of etch primer to IS:5666.
- (ii) One coat of zinc chrome primer to IS:104 with the additional proviso that zinc chrome to be

used in the manufacture of primer shall conform to type 2 of IS:51.

- iii) Two coats of aluminium paint to IS:2339 brushing or spraying as required. One coat shall be applied before the fabricated steel work leaves the shop. After the steel work is erected at site, the second finishing coat shall be applied after touching up the primer and the finishing coat if damaged in transit.

39.2.2 For locations where girders are exposed to corrosive environment i.e. flooring system of open web girders in all cases, girders in industrial, suburban or coastal areas etc., protective coating by metallising followed by painting as mentioned in clause 39.2.1 or by painting using epoxy based paints as per the following painting schedule may be applied:

i) Surface Preparation

- a) Remove oil/grease from the metal surface by using petroleum hydrocarbon solvent to IS:1745.
- b) Prepare the surface by sand or grit blasting to Sa 2-1/2 to IS:9954 i.e. near white metallic surface.

(ii) Painting

(a) Primer Coat

Apply by brush/airless spray two coats of Epoxy Zinc Phosphate primer to RDSO Specification No. M&C/PCN/102/86 to 60 microns min, dry film thickness(DFT) giving sufficient time gap between two coats to enable the first coat of primer to hard dry.

(b) Intermediate Coat

Apply by brush/ airless spray one coat of Epoxy Micaceous Iron Oxide paint to RDSO Specification No. M&C/PCN/103/86 to 100 microns minimum DFT of 100 and allow it to hard dry.

(c) Finishing Coat

Apply by brush/airless spray two coats of polyurethane aluminium finishing to RDSO Specification No. M&C/PCN-110/88 for coastal locations or polyurethane red oxide (red oxide to ISO 446 as per IS:5) to RDSO Specification M&C/PCN-109/88 for other locations to 40 microns minimum DFT giving sufficient time gap between two coats to enable the first coat to hard dry. The finishing coats to be applied in shop and touched after erection if necessary.

39.2.3 For other locations, protective coating by painting as per painting schedule given below may be applied:

a) Primer coat

One coat of ready mixed paint zinc chrome priming to IS:104 followed by one coat of ready mixed paint red oxide zinc chrome priming to IS:2074.

or

Two coats of zinc chromate red oxide primer to IRS:P-31.

b) Finishing coat

Two finishing coats of red oxide paint to IS:123 or of any other approved paint shall be applied over the primer coats. One coat

shall be applied before the fabricated steel work leaves the shop. After the steel work is erected at site, the second finishing coat shall be applied after touching up the primer and the finishing coat if damaged in transit

39.2.4 Where the life of protective coating is required to be longer to avoid frequent paintings, the problem of accessibility of locations and for other locations where metallising or epoxy based painting is recommended vide Clause 39.2.2 but there are no facilities available for the same, protective coating by painting as per following painting schedule may be applied with the approval of the Purchaser:

a) Primer coat

One coat of ready mixed zinc chrome priming to IS:104 followed by one coat of zinc chrome red oxide priming to IS:2074.

b) Finishing Coat

Two coats of aluminium paint to IS:2339 shall be applied over the primer coats. One coat shall be applied before the fabricated steel work leaves the shop. After the steel work is erected at site, the second coat shall be applied after touching up the primer and the finishing coat if damaged in transit.

39.3 Surfaces which are inaccessible for cleaning and painting after fabrication shall be applied one heavy coat of zinc chrome red oxide priming to IS:2074 before being assembled for rivetting/welding.

39.4 All rivets, bolts, nuts, washers etc. are to be thoroughly cleaned and dipped into boiled linseed oil to IS:77

39.5 All machined surfaces are to be well coated with a mixture of white lead to IS:34 and Mutton tallow to IS:887.

39.6 For site painting the whole of the steel work shall be given the second finishing coat after finally passing and after touching up the primer and finishing coats if damaged in transit.

40. Name Plate

40.1 A neat casting bearing the name of the Contractor, the place and year of manufacture, drawing number, the contract number and the standard of loading to be specified by the Purchaser shall be bolted conspicuously on each span. The drawing of the name plate shall be approved by the Engineer.

41. Erection Mark

41.1 Every portion of the work shall be distinctly stencilled with paint with letter size not less than 10 mm for guidance in the erection in the field, and stamped with the letters specified in the drawings. In the case of non-interchangeable work, the system of marking shall be in accordance with the drawings prepared by the tenderer and approved by the Purchaser.

42. Packing

42.1 All projecting plates or bars shall be kept in shape by timber or angle bars spiked or bolted to them, and the ends of the chord lengths, end posts and plate girders at their shipping joints shall be protected and stiffened so as to prevent damage or distortion in transit as the Inspecting Officer may direct.

42.2 All threaded ends and machined surfaces are to be efficiently protected against damage in transit. The parts shall

be sent out in lengths convenient for transport.

42.3 All straight bars and plates except small pieces are to be sent out in convenient bundles temporarily rivetted or bolted together or bound with wrought iron or suitable wire as the Inspecting Officer may direct. All rivets, bolts, nuts, washers, plates under 300 mm square and small articles generally are to be packed separately for each span in cases each weighing, when full, not more than 350 kg, or in strong petroleum casks, or in barrels approved by the Inspecting Officer. If not entirely filled by the contents the space left shall be closely packed with wood shaving or other suitable material. Bolts and rivets of different sizes shall be separately packed in bags, each bag having a label indicating its contents. A list of the contents shall be placed in the top of each case or cask.

42.4 In the case of imported material all cases shall be made of 32mm boards with ends nailed with 90mm wire nails strengthened by battens and 38mmx 1.6mm (No. 16 BG) hoop -iron and made thoroughly secure for transit to India. All casks shall be in sound condition, and if not entirely filled by the contents the space left shall be closely packed with wood-wool or other suitable material. The heads shall be firmly secured by means of hoops in the usual way, and in addition each head shall be further secured by a strong wooden batten and not less than two strips of 1.6mm(No.16 BG) hoop-iron passing over the head and nailed to the staves on both sides. The hoop-iron shall be long enough to pass over two hoops on each side of the cask and be nailed in such a manner that the hoops cannot slack back. Bolts and rivets of different sizes shall be packed in a separate canvas bags, each bag having a label in dictating its contents. End field holes to be bolted in case of members having split in plate and channels.

43. Despatch or Shipping Marks

43.1 Each package, case or bundle is to have clearly stencilled on it in good oil paint the address as stated in the order of contract, gross and net weight description of contents and such marks as may be required by the Purchaser must be shown against each item in the invoice. The Contractor is to provide necessary stencil plates for marking. Every piece of bundle shall be marked and in the case of material (shipped to India) all cases or casks shall be clearly cut or branded, not merely painted, with their net and gross weights and with such shipping marks and other particulars as the Inspecting Officer may direct and each bundle shall also have a metal label securely attached with wire stamped with similar marks. The marking shall be done with thick oil paint and in such a manner that it cannot be washed off or obliterated.

44. Loading

44.1 All trucks or wagons are to be loaded to as near their full capacity as is consistent with safe transport. While loading the material in wagon, truck or trailer, care should be taken that heavier material is loaded first and lighter material is kept on top so that lighter material is not damaged due to heavy weight. While transporting the material by road, adequate safety precautions shall be taken as per extant instructions.

44.2 The Contractor shall apply all dunnage and lashing required to hold the material securely in position free of charge.

44.3 While handling any girder or girder component it shall be ensured no damage to material takes place in the form of dent/cut mark etc. Wooden blocks, rubber pads shall be used to avoid direct contact

between materials to be handled and handling equipment.

45. Weight of Steel Work for Payment

45.1 Any steel work the weight of which differs by more than 2.5% from the calculated weight determined from the nominal weight of the sections shall be liable to rejection.

45.2 Payment shall be made on the tendered weight to be calculated in accordance with the nominal weight of the sections as specified on the contract drawings. An addition in weight for welds and rivet heads should either be specified in the schedule or be made as follows:

- a) 3% in case of rivetted or composite (rivetted and welded) work; and
- b) 1 % in case of purely welded work.

45.3 Should the actual weight fall short of the calculated weight by more than 2.5%, the material if accepted, will be paid for the actual weight only. Should the actual weight exceed the actual calculated weight, payment will be made for calculated weight only.

45.4 No separate payment shall be made for the items mentioned in clause 24.

45.5 In the event of a dispute arising as to the weight of a portion of steelwork, a weightment shall be made in the presence of the Inspecting Officer.

46. Quantities

46.1 In case where the estimated quantities are given with the schedule, it must be understood that the Purchaser will not be responsible for their accuracy and if the Contractor makes use of them in

preparing his/her tender, he/she does so at his/her own risk, as he/she will not be entitled to make any claim or demand nor to raise any question whatsoever, on account of any error or miscalculations in or misunderstanding of the said quantities, as these are given for the convenience of the Purchaser.

47. Tracings and Printings

47.1 Excepting in the case of standard spans fabricated without any modifications to the standard drawings the Contractor shall supply free of charge, one set of neatly executed tracing on linen. They shall be fully dimensioned and contain all erection marks, notifications as to the colour the work has been printed, the name of the Contractor and any alterations from the contract drawings, which may have been made in executing the work. The drawings shall conform to standard sizes as given in IS:962 and shall not exceed A₀ size. The drawings shall not be folded but rolled outwards on a roller, in addition to three sets of full size copies on strong paper made by an approved process.

48. Rivets and Bolts Lists

48.1 The Contractor shall also supply, without charge, three complete lists of the rivets, bolts, service bolts, washers and drifts required for erecting the work at site, showing the parts of the work to which the various rivets and bolts belong and having each item marked so as to indicate the particular case in which it will be found.

49. Photographs

49.1 If required by the Purchaser the Contractor shall also supply without charge, two sets of large well-executed, unmounted photographs of the first span of each description of plate girder or truss bridge when erected, taken from two points

of view and showing the erection marking as clearly as possible Photographs of rolled beam, trough girder or trough plate girder bridges will not be required.

50. Attestation of Tracings etc.

50.1 The tracings, photographs and lists shall be examined and signed by the Inspecting Officer. They shall be supplied with the first instalment of the work delivered.

51. Inclusive Price

51.1 The cost of all painting, temporary erection and tests at the Contractor's works, marking, packing and delivery F.O.R. or C.I.F. as called for in the schedule is to be included in the price named on the tender. The cost of erection at site, if done by the Contractor, is to be entered separately.

52. Deviations from this Specification

52.1 Should a tenderer desire to depart in any respect from the provisions of this Specifications either on account of manufacturing practice or for any other reasons, he/she must do so in an alternative tender which may not be considered, with a covering letter explaining in detail each and every departure he/she proposes to make from the Specification.

52.2 Manufacturer's standard specification may be submitted but all discrepancies must be carefully drawn attention to, both in covering letter and in appendices to be annexed to the specification.

52.3 The intention is to adopt manufacturer's standard equipment as far as possible but these standards must in all respects comply with the conditions of this Specification regarding safety from break-down, output, capacity, performance etc.

53. Alterations in Work

53.1 The Contractor shall not in any case or in any circumstances have authority to make any alterations in, modifications of, substitution for, addition to, or omission of work or any method or system of construction, unless an alteration order in writing directing such alteration, modification, substitution, addition, omission or change shall have been given by the Purchaser prior to the commencement of the work or part of work nor shall the Contractor be entitled to any payment for or in respect of any such alteration, modification, substitution, addition, omission or change may have been actually made and executed and no course of conduct shall be taken to be a waiver of the obligation and conditions hereby imposed.

53.2 All altered, modified, substituted, additional and changed work, labour and materials and all omitted work shall be valued by the Purchaser on the basis of the rates specified in the schedule.

54. Additional Specification for Locomotive Turn- Tables

54.1 General - The locomotive turn-tables shall be complete in every respect including rails for the deck and pathway, locking pockets and gear with turning handles or levers, foundation bolts and plates, supply of grease for the bearings, and set of case-hardened black finished spanners for the suspension bolts etc. all necessary fish-plates and bolts, spikes etc. for the table and pathway rails, and all bolts, rivets and other fastenings requisite for the erection of the locomotive turn-tables together with the percentage for spares given in clause 24 above shall be included in the contract. Unless otherwise specified a complete spare set of balls and

rices shall be supplied with each locomotive turn-table.

54.2 Steel Forgings and Bars for Shafts

- Steel forgings and bars for shafts shall be made from Class 4 steel to IS:2004.

54.3 Ball and Roller Bearings

- Ball and roller bearings when and where used shall be of approved make.

54.4 Case Hardened Steel for Bearings

- Case hardened steel for bearings shall be of Class I Steel to IS:1875.

54.5 Balance/Race Wheels

- Balance/Race wheels shall be of chilled cast iron to IRS R19 or cast steel to IRS M2 and the dimensions shall be as shown on the drawings.

54.6 Split Cotters

- Flat split cotter shall be to IS:2638.

54.7 Split Cotter Pins

- Split cotter pins shall be to IS:549.

54.8 Set Screws

- Set screws shall be to IS:1364.

54.9 Table and Race Rails

- Rails shall be to IRS T-12 to T-18.

54.10 Suspension Bolts

- The screwed ends of the steel suspension bolts shall not be welded but formed from the solid bar.

54.11 Bearing Caps

- Bearing caps shall be provided with two eye bolts for lifting.

54.12 Case Hardening

- All case hardening shall be done in a furnace with animal charcoal or other approved composition. No potash hardening will be allowed. A test piece of the material used 30 mm dia. turned and finished must be put in the furnace, with the articles to be case

hardened. This piece after being hardened must be submitted to the Inspector for his/her approval. When broken, the depth of the case hardening must be at least equal to that specified for the centre pivots.

54.13 Cast Iron/Cast Steel Centre Pillar

- The cast iron centre pillar shall be finished on top to suit the type of bearing specified by the Purchaser. The oscillation of the table shall be taken by a cup and pivot fitted into a cast steel container and the bearing cup respectively. The cup and pivot shall be machined from well hammered Class I Steel forgings to IRS M-3. After being machined the bearing surfaces of the cup and pivot shall be compressed by the hydraulic pressure. The cup and pivot shall then be case hardened to a depth of not less than 3.0 mm (1/8 inch) and then accurately finished to the correct profile. In the case of ball bearings the housing shall be dust proof and oil retaining. Adequate means shall be provided for lubrication of the centre bearing and the pivot.

54.14 Race Wheels

- The pathway wheels are to be fitted with ball bearings of approved make and are to run on steel spindles fixed in cast iron brackets, securely bolted to steel joists. Plain bearing will be accepted if specified by the Purchaser.

54.15 Locking Pockets

- Locking pockets for one position of the locomotive turn-table only are to be provided unless otherwise stated by the Purchaser.

54.16 Erection and Testing at Contractor's Works

- The locomotive turn-table shall be temporarily erected complete at the Contractor's works for inspection by the Inspecting Officer so that accuracy of fit and perfection of workmanship may be ensured. The erection work shall be done as indicated in clause 32.1. Each locomotive turn-table shall also be tested

for deflection which under specified load shall not exceed the amount specified by the Purchaser in accordance with the design adopted. The locomotive turn-table shall be turned not less than 15 times in each direction with an equivalent uniformly distributed test load in the presence of the Inspecting Officer and to his/her satisfaction

54.17 Contractor's Guarantee - The Contractor shall guarantee for supply of materials, and working of the locomotive turn-table for a period of one year after

receipt of materials at site or 3 months after the date of erection whichever is earlier.

54.18 Removal of Unused Material etc - On the completion of the work the Contractor shall remove all used and surplus material, plant, stagings and refuse, or other material produced by his/her operations and shall leave the site in a clean and tidy condition.

54.19 Weight of Steel Work for Payment- Erection shall be paid for on the weight as per Clause 45.

Records to be Maintained

1) JIGS REGISTER

This register shall be maintained for keeping record of details of jigs, their approval and modification/rectification to the jigs. One page should be allotted for each jig and details mentioned in the following proforma:-

1. Description of jig:
2. Jig No.:
3. Shipping mark of the component for which jig is made:
4. Drawing No. for the component:

Date of inspection	Observation/inspection notes	Compliance action	Initial of Supervisor Incharge
1	2	3	4

In the beginning of Register, a statement of jigs shall also be placed in the following proforma:

Jig No.	Description of Jig.	Shipping mark of the component.	Drg.No. as per which jig is made/modified	Inspecting official's approval details
1	2	3	4	5

2) RIVET CHECKING REGISTER

This register shall be maintained for keeping record of rivet quality checking and replacement of defective rivets. Register shall be maintained in the following proforma:-

Component description	Date of rivetting	Rivetting party	Number and nature of defective rivets	Number of defective rivets replaced	Initial of Supervisor Incharge.
1	2	3	4	5	6

After rivetting, component has been inspected and defective rivets have been replaced, the Supervisor Incharge of rivetting should put a stencil mark on the component to this effect.

3) MATERIAL OFFERING AND INSPECTION REGISTER

This register shall be maintained separately for each work order for keeping record of material offered for inspection, inspection remarks and passing details. One page should be allotted for individual members or fittings. Proforma shall be as under:-

1. Description of component/fitting:
2. Shipping mark:
3. Quantity required per span:

Span No.	Initial of Supervisor offering material for inspection.	Inspecting officials Remarks	Compliance action	Seal & initial of Inspecting official	Despatch & consignee details.
1	2	3	4	5	6

4) RDSO INSPECTION NOTES AND COMPLIANCE REGISTER

This register shall be maintained for record of compliance action taken on RDSO Inspection notes. In this register one copy of the inspection note received from RDSO shall be pasted and compliance action recorded against each item.

5) WELDING PROCEDURE DATA REGISTER

In this register complete details of welding of welded girders shall be maintained in the proforma as under:

Name of work: _____

Contract/Work Order No. _____

Span No. _____

Date of welding	Girder component and its Sl.No.	Weld joint description	Name of welder/Ticket No.	WPSS No. followed
1	2	3	4	5

Welding consumable used		Welding parameters			Weld repair details	Run on/Run off tabs. No. if any	Radiograph no. if any	Initial of Supervisor Incharge.
Electrode / wire	Flux	Current (amp.)	Arc Voltage (volt)	Travel Speed (m/min)	11	12	13	14
6	7	8	9	10				

The welding data record to be submitted to RDSO while offering the welded girders for inspection, shall be prepared based on the details recorded in this register.

6) RADIOGRAPHIC INSPECTION REGISTER

Record of radiographic inspection of welded girders shall be maintained in the register in the proforma given below:

Name of work	Span No.	Girder Part	Weld joint description	Date of radiographic inspection.	Radiograph No.	Observation	Result	Initial of Supervisor Incharge.
1	2	3	4	5	6	7	8	9

7) STATEMENT OF MATERIAL TEST CERTIFICATES

Name of Work _____

Contract/Order No. _____

Span No. _____

Girder Component description and identification No.	Type and Size of rolled section	Material Test Certificate No.	Cast No.	Steel quantity as per the test certificate	Steel Manufacturer/ Supplier	Initial of Supervisor Incharge
1	2	3	4	5	6	7

One page should be allotted for each span.

Manufacturing Tolerances

1. Plate girders					
			Tolerances in mm		Notation in the Figure No.1
			(plus)	(minus)	
	(a)	Overall length of the girder	6	3	a
	(b)	Distance between centres of bearings	1	1	b
	(c)	Depth over angles	3	1	c
	(d)	Corner of flange angle to edge of web at any place	0	2	d
	(e)	Diagonal at either end of the assembled span	3	3	e
	(f)	Centres of intersection of diagonals with girder flange measured along the girder flange	3	3	f
	(g)	Butting of compression ends			
		i) throughout	0	0.15	g
		ii) locally	0	0.25	g
	(h)	Butting edge at web splices	0	1	h
	(i)	Straightness of girder bottom laid on the ground and checked with piano wire:			
		(i) vertical plane			
		Convexity	0	3	j
		Concavity	0	0	j
		(ii) Horizontal plane	2	2	j
2. Open web girders					
	(a)	Over-all length of girders	1	1	k
	(b)	Distance between centre to centre of bearings	1	1	l
	(c)	Cross diagonals of assembled bays	1	1	m
	(d)	Centre to centre of cross girders	1	1	n
	(e)	Centre to centre of rail bearer	1	1	p
	(f)	Panel length in lateral bracing system	1	1	q

(g)	Distance between inter section line of chords vertical and horizontal	1	1	r
(h)	Butting edges of compression members:			
	(i) throughout	0	0.15	s
	(ii) locally	0	0.25	s
(i)	Twist in members	0	0	t
(j)	Lateral distortion between points of lateral supports	.001 L	.001 L	u

3. Holes-

(a)	Between any two holes in group	0.5	0.5	v
(b)	Between holes of one group and another	1	1	w
(c)	Edge distance	0.5	0.5	x
(d)	Distance of „GO' gauge open holes in two or more thicknesses	0	0.8	y

(On nominal diameter of hole)

4 Special Fabrication Tolerances as applicable to Welded Plate Girder.

	Description.	Tolerances in mm
1.	Depth at the centre of web	+2 to -1
2.	Flange out of square for compression member and beams	1/200 or 3 max From edge whichever is less.
3.	Displacement of vertical axis of the web with reference to flange.	2
4.	Box width of member	0 to +3
5.	Verticality of stiffener or diaphragm out of plumb.	2
6	Overall length of girder	+ 6 to -3
7	Depth of the girder at the ends	+ 3 to -1
8	Depth of the girder at the centre of span	+ 2 to -1
9	Distance between centre of bearings	+ 1 to -1
10	Diagonal at either end of assembled span	+ 3 to -3

11

An allowable limit for web buckling or undulation shall be flatness at right angles to plate surface measured parallel to longer side in either direction calculated from the formulae

$$\Delta_x = \frac{G}{165} \sqrt{\frac{\sigma_y}{355}} \quad \text{or } 4\text{mm which ever is the lesser.}$$

Where

Δ_x = Maximum deviation from straightness within a specific gauge length other values are constant

σ_y = Yield stress of steel in N/mm²

G = length of measuring gauge in meter

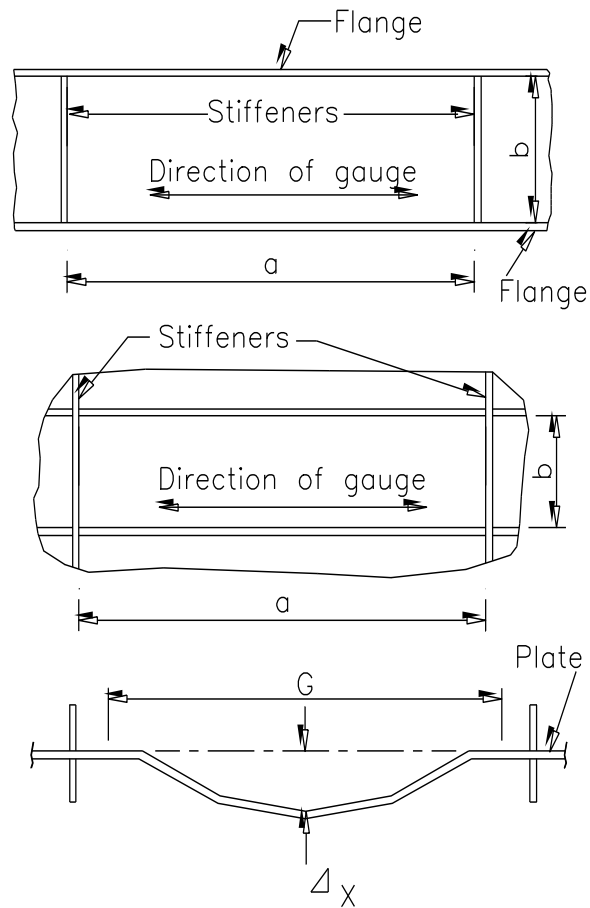

(G= a where a<2b and G=2b where a>2b)



Erection of Open Web Girder Span

1. The joints of the chords shall be drifted, bolted and preferably rivetted to their geometric outline.
2. All other members are to be elastically strained into position by external forces, so that as many holes as possible are fair when filled with rivets.
3. Drifting of joints shall be avoided as far as possible, and when necessary should be done with greater care and under close expert supervision. Hammers not exceeding 1 kg.(2 lb) in weight should be used with turned barrel drifts and a number of holes drifted simultaneously, the effect of the drifting being checked by observation of adjacent unfilled holes.
4. The first procedure during erection consists of placing camber jacks in position on which to support the structure. The camber jacks should be set with their top level and with sufficient run-out to allow for lowering of panel points except the centre by the necessary amount to produce the required camber in the main girders. It is essential that the camber is accurately maintained throughout the process of erection and it should be constantly checked. The jacks shall be spaced so that they will support the ends of the main girders and the panel points. The bottom chord members shall then be placed on the camber jacks carefully levelled and checked for straightness and the joints made and rivetted up.
5. The vertical and diagonal web members, except the end posts, shall then be erected in their proper position on the bottom chords. Temporary top gussets, the positions of the holes in which they are corrected, for the camber change of length in the members, should be used to connect the top ends of the members. This will ensure that the angles between the members at the bottom joints are as given by the nominal outline of the girders. The verticals and diagonals shall then be rivetted to the lower chords.
6. All panel points, except the centre, shall now be lowered by the amount to produce the correct camber in the main girders as shown on the camber diagram.
7. The top chord shall be erected piece by piece working symmetrically starting from the centre outwards, each piece being cambered in turn
8. The temporary top gussets, if used, shall be replaced by the permanent gussets in the same sequence as the erection of the top boom members.
9. The end posts shall be erected last. The upper end connection should preferably be made first and if there is no splice in the end raker, the final closure made at the bottom end connection. If there is a splice, the final closure should be made at the splice.
10. When cantilever method of erection is used, the above procedure does not apply.

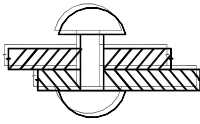
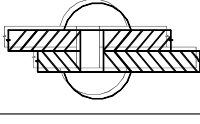
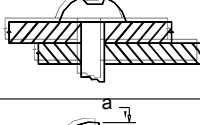
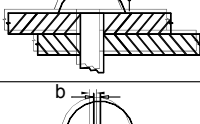
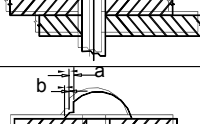
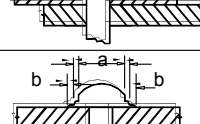
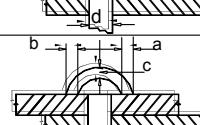
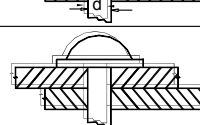
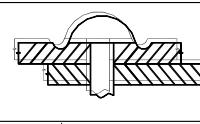
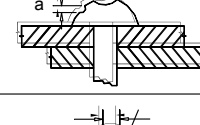
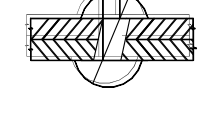
PERMISSIBLE DEVIATIONS FOR DRIVEN RIVETS

S.NO.	DESCRIPTION OF DEVIATIONS	SKETCH	TOLERANCE
1.	SHANKING OR SHIFTING OF THE HEAD UNDER THE KNOCKS OF HAMMER.		NOT ALLOWED
2.	CAULKING OF THE HEAD		NOT ALLOWED
3.	IMPROPER BEARING OF THE HEAD ON THE ELEMENT WHILE RIVETTING ALONG THE ENTIRE CONTOUR OF HEAD.		NOT ALLOWED
4.	IMPROPER BEARING OF THE HEAD ON THE ELEMENT WHILE RIVETTING ALONG THE ENTIRE PART OF CONTOUR OR RIVET.		NOT ALLOWED
5.	PRESENCE OF CRACKS IN THE HEAD.		NOT ALLOWED
6.	NOTCH IN THE HEAD.		2 mm
7.	SHIFTING OF HEAD FROM THE AXIS OF RIVET.		$b \leq 0.1d$
8.	BAD SHAPE OF HEAD ALONG THE PART OF CONTOUR OF RIVET.		$a + b \leq 0.1d$
9.	BAD SHAPE OF HEAD ALONG THE ENTIRE CONTOUR OF RIVET.		$a + b \leq 0.1d$
10.	HEAD OF REDUCED DIMENSION.		$a + b \leq 0.1d$ $c \leq 0.5d$
11.	CROWN NEAR THE HEAD.		NOT ALLOWED
12.	NOTCHING OF STEEL BY SNAP.		NOT ALLOWED
13.	UNEVENNESS OF THE SURFACE OF THE HEAD.		$a \leq 0.3 \text{ mm}$
14.	OBLIQUE RIVETTING.		DEVIATION UP TO 3% OF THICKNESS. THICKNESS OF JOINT ELEMENTS BUT NOT MORE THAN 3mm.

2. Proforma for Welding Procedure Qualification Record

NAME AND ADDRESS OF FABRICATOR

1. Description of weld joint:
2. Welding procedure specification no.:
3. Name of welder:
4. Date of preparation of test piece:
5. Dimensions of test piece:
6. Base Metal:
7. Welding Process:
8. Welding position:
9. Welding Current: Type:
Polarity:
10. Weld joint design details:
11. Welding consumables:
- 11.1 Electrode/wire Class:
Dia:
Brand:
- 11.2 Flux Class:
Type:
Brand:
- 11.3 Shielding gas:
12. Welding parameters:

Weld pass No.	Electrode wire dia (mm)	Current (amp)	Arc voltage (volt)	Wire feed speed (m/min.)	Travel speed (m/min.)	Electrical stick out (mm)	Shielding gas flow rate (lit/min.)
1	2	3	4	5	6	7	8

13. Preheating and interpass temperature:

14. Results of Qualification Tests:

Test	Specimen No.	Result.
1	2	3
Non-destructive tests: i) Visual examination: ii) Dye penetrant test: iii) Magnetic particle test: iv) Radiographic/Ultrasonic test: Destructive tests: i) Macro-examination: ii) Hardness survey: iii) Fillet weld fracture test: iv) Transverse tensile test: Tensile strength Yield Stress Location of fracture v) All-weld tensile test: Tensile strength Yield Stress Elongation % vi) Guided bend test: Root bend test Face bend test Side bend test vii) Any other tests:		

Signature _____
 Designation _____
 Date _____
 (for & on behalf of Fabricator).

Tolerances & Specification for Knuckle and Roller Bearings

1. Rollers

No roller shall vary in diameter, from that shown on the contract drawings, by more than ± 0.04 mm.

2. Knuckle castings and pins (Interchangeable work)

a) Knuckle Pin

The diameter shall not be greater than D, nor less than $D - 0.2$ mm.

b) Knuckle Castings

The knuckle castings must be bored greater than D, but not greater than $D + 0.3$ mm.

Where D, in all cases is the diameter given on the contract drawings.

3. Knuckle castings and pins(non-interchangeable work)

If sets of bearings are not made interchangeable but are made separately and the pins and knuckles all fitted together than the minus tolerance on the pin, and the plus tolerance on the bore of the knuckles may be varied provided that the difference between the diameter of the pin and the diameter of the knuckle does not exceed 0.5mm. also in this case all sets of bearing are to be given a consecutive number and each component part shall have this allotted number stamped upon it and encircled in white paint in the manner shown on the sketch.

4. Marking

Accurate centre marks should be made on the four sides of the bottom slab of the bearing to facilitate positioning during erection.

5. Thickness of castings (Interchangeable and non inter-changeable work)

No minus tolerance will be allowed in the thickness of any part of any of the castings. The edges of all ribs shall be of the thickness shown on the contract drawings and shall be parallel throughout their length.

Specification for Metallising with Sprayed Aluminium for Bridge Girders

1. Surface Preparation

The surface shall be thoroughly cleaned and roughened by compressed air blasting or centrifugal blasting with a suitable abrasive material in accordance with Clause 3 of IS:6586. Immediately, before spraying it shall be free from grease, scale, rust, moisture or other foreign matter. It shall be comparable in roughness with a reference surface produced in accordance with appendix A of IS:5905 and shall provide an adequate key for the subsequently sprayed metal coating

2. Metal Spraying

The metal spraying shall be carried out as soon as possible after surface preparation but in any case within such period that the surface is still completely clean, dry and without visible oxidation. If deterioration in the surface to be coated is observed by comparison with a freshly prepared metal surface of similar quality which has undergone the same preparation, the preparation treatment should be repeated on the surface to be coated.

The wire method shall be used for the purpose of metallising the diameter of the wire being 3mm or 5mm. Specified thickness of coating shall be applied in multiple layers and in no case less than 2 passes of the metal spraying unit shall be made over every part of the surface. At least one layer of the coating must be applied within 4 hours of blasting and the surface must be completely coated to the specified thickness within 8 hours of blasting.

2.1 Purity of Aluminium

The chemical composition of aluminium to be sprayed shall be 99.5% aluminium conforming to IS:2590.

2.2 Appearance Of The Coating

The surface of the sprayed coating shall be of uniform texture and free from lumps, coarse areas and loosely adherent particles.

2.3 Thickness Of The Coating

The nominal thickness of the coating shall be 150 μ (microns).The minimum local thickness, determined in accordance with procedure given in clause 3.1 below, shall be not less than 110 μ (microns).

3. Shop Painting

Any oil, grease or other contamination should be removed by thorough washing with a suitable thinner until no visible traces exist and the surfaces should be allowed to dry thoroughly before application of paint. The coatings may be applied by brush or spray. If sprayed, pressure type spray guns must be used. One coat of wash primer to IS:5666 shall be applied first. After 4 to 6 hours of the application of the wash primer, one coat of Zinc chrome primer to IS:104 with the additional proviso that zinc chrome to be used in the manufacture of primer shall conform to type 2 of IS:51 shall be applied. After hard drying of zinc chrome primer, one coat of Aluminium paint to IS:2339 (brushing or spraying as required) shall be applied.

4. Site Painting

After the steel work is erected at site a second cover coat of Aluminium paint to IS:2339 (brushing or spraying as required) shall be applied after touching up the primer and the cover coat given in the shop if damaged in transit

5. Method for the Determination of Local Thickness

5.1 Equipment

Any magnetic or electro-magnetic thickness meter that will measure local thickness of a known standard with an accuracy of ± 10 percent.

5.2 Calibration of Instrument

Calibrate and check the meter on one of the following standards(as appropriate):

(I) (Applicable to magnetic and electro-magnetic meters other than the pull-off type)
A soft brass shim ,free from burrs, in contact with the grit-blasted surface of the base metal prior to its being sprayed. The thickness of the shim shall be measured by micro meter and shall be approximately the same as the thickness of the coating.

(ii) A sprayed metal coating of uniform known thickness approximately the same as the thickness of the sprayed coating to be tested, applied to a base of similar composition and thickness to the article being sprayed, grit-blasted in accordance with Clause 1.

5.3 Procedure

For each measurement of local thickness, make an appropriate number of determinations, according to the type of instrument used.

With instrument measuring the average thickness over an area of not less than 0.645 cm^2 , the local thickness shall be the result of the one reading.

With instruments having one or more pointed or rounded probes, the local thickness shall be the mean of three readings within a circle of 0.645 cm^2 area.

With meters having two such probes, each reading shall be the average of two determinations with the probes reversed position.

6. Method Of Test For Adhesion

Using a straight edge and hardened steel scribe which has been ground to a sharp 30 degree point, scribe two parallel lines at a distance apart equal to approximately 10 times the average coating thickness. In scribing the two lines, apply enough pressure on each occasion to cut through the coating to the base metal in a single stroke.

7. Inspection

7.1 Determination of Local Thickness

The minimum local thickness shall be determined by the method described above.

7.2 Adhesion

The sprayed metal coating shall be subjected to an adhesion test using the method described above. If any part of the coating between the lines breaks away from the base metal, it shall be deemed to have failed the test

Articles, which have been rejected shall have the defective sections blasted clean of all sprayed metal prior to respraying. Where the rejection has been solely due to too thin a coating, sprayed metal of the same quality may be added provided that the surface has been kept dry and is free from visible contamination.

MANUFACTURING TOLERANCES IN GIRDERS

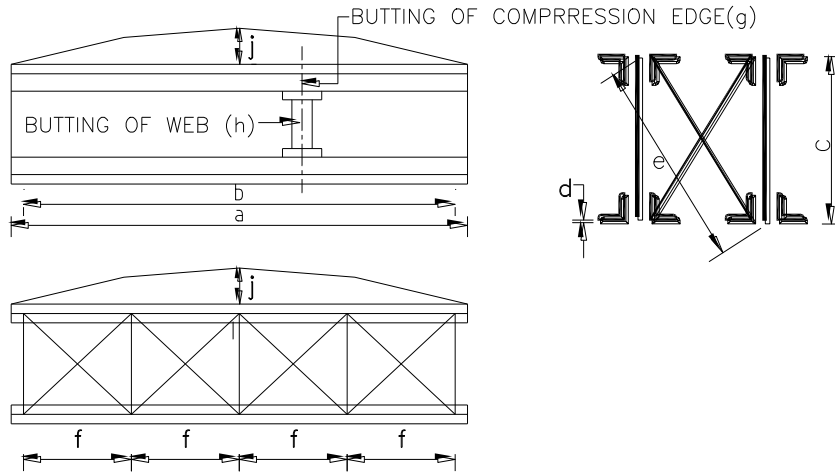
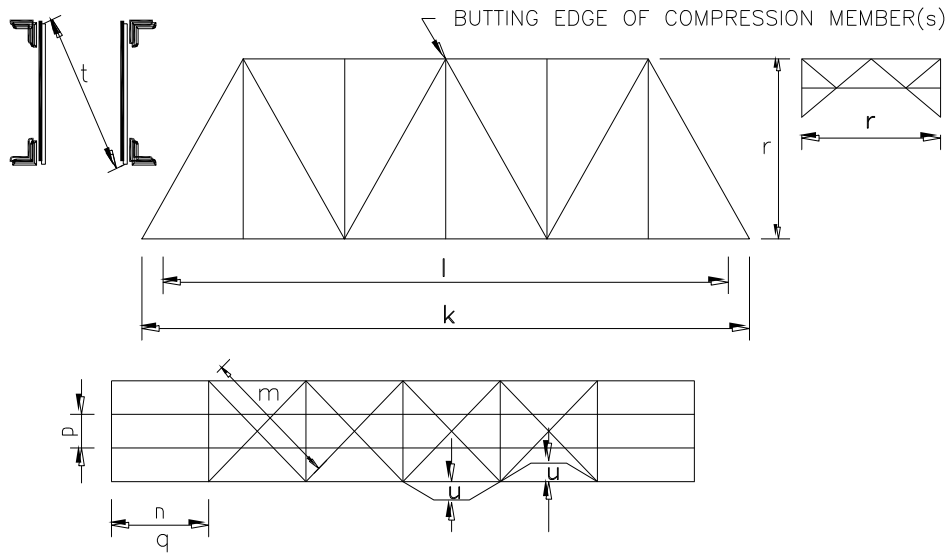
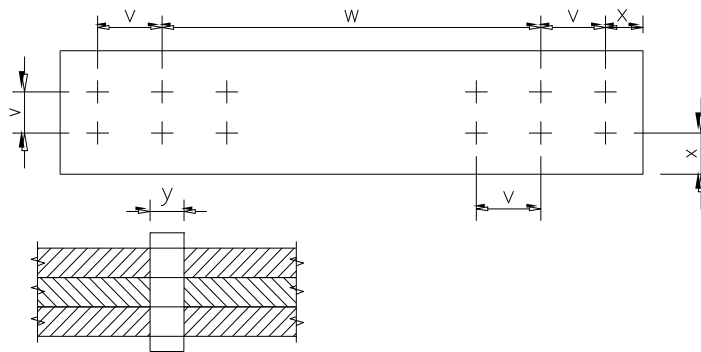

PLATE GIRDERS



OPEN WEB GIRDERS



HOLES IN MEMBERS

PARALLEL BARREL DRIFT

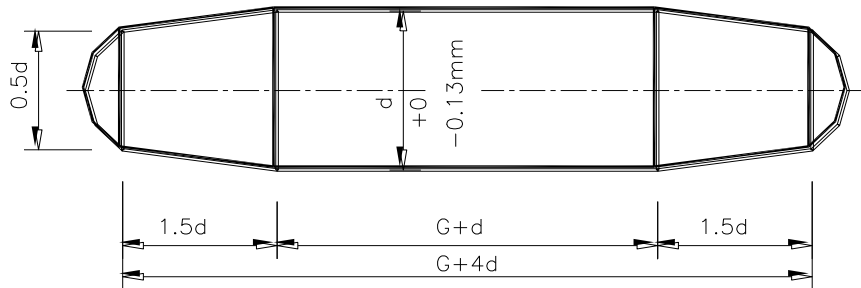

d. IS THE NOMINAL DIAMETER OF THE HOLE.
 G. IS THE COMBINED THICKNESS OF THE METAL THROUGH WHICH THE
 DRIFT HAS TO PASS.
 STEEL- IS: 1875 OR IS: 7283

FIG.-2

(REF. CLAUSE 19 & 20)

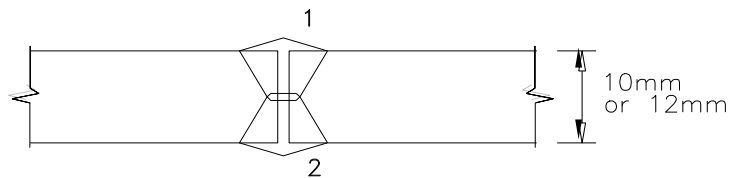

Sketch showing sequence of square butt welding

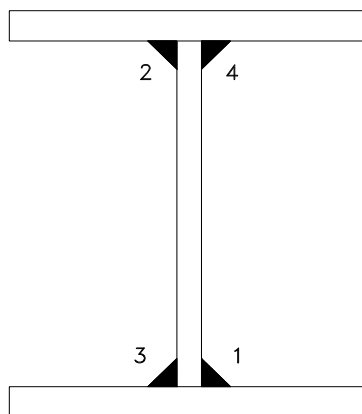

Sketch showing the sequence of fillet welding
for fabricating the I-section

FIG.-3

(REF. CLAUSE 27)

FIG.-4
(REF. CLAUSE 31)

ROLLER & ROCKER BEARING FOR BRIDGES

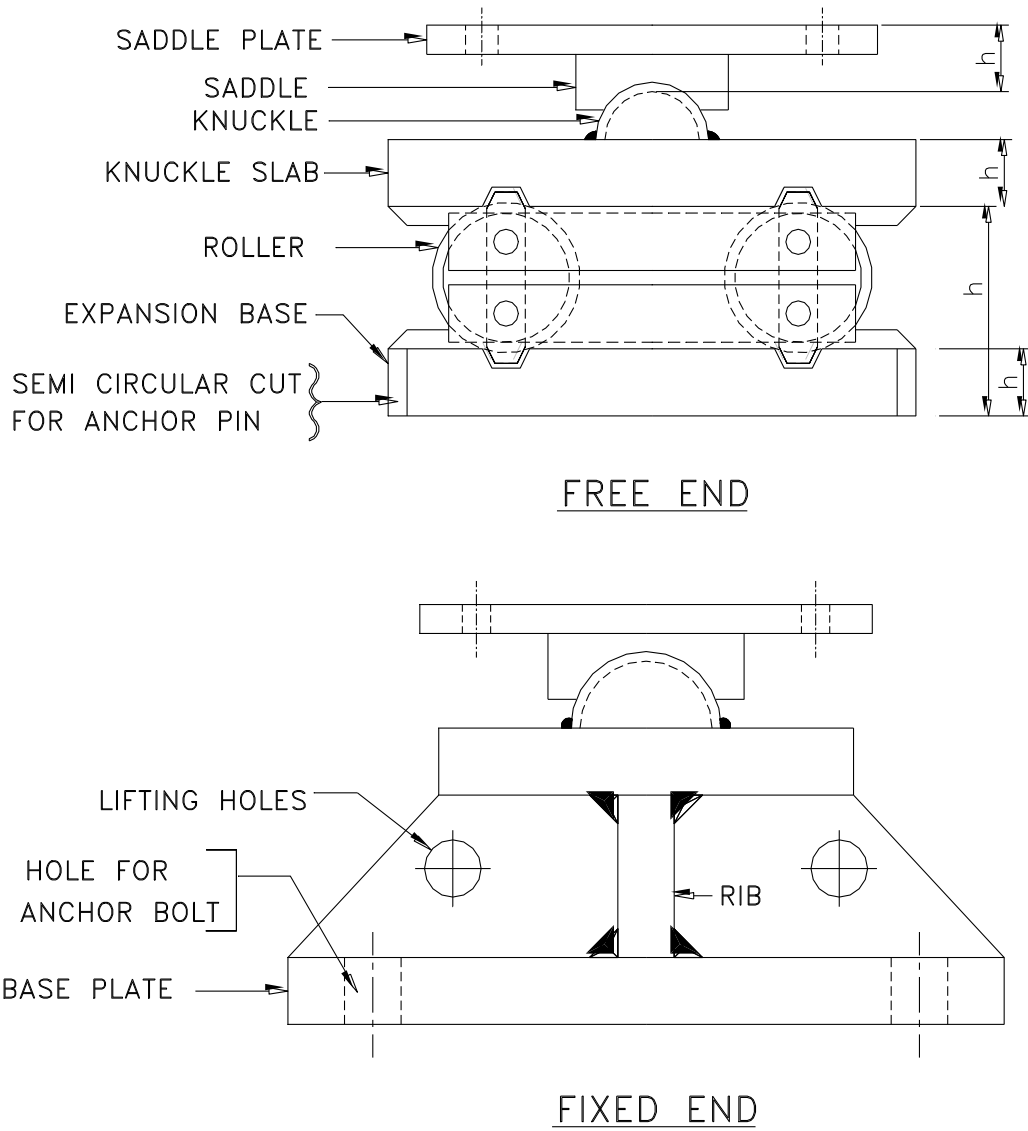

h = HEIGHT OF COMPONENT CASTING AS GIVEN ON CONTRACT DRAWING.

The tolerance on the height of any component casting shall not exceed 0.5mm.

FIG.-4
(REF. CLAUSE 31)