

Build Your Value In A Competitive World

October 15-17, 2015 - Kelowna, BC

Annual Conference and AGM

2015 NBCC – Part 4 Summary of **Proposed** Changes (not including seismic)

As proposed by SCSD
Standing Committee on Structural Design



Professional Engineers
and Geoscientists of BC



Engineers

Grant Newfield

Principal

Read Jones Christoffersen Ltd.

NBCC - Disclaimer

- Current Status of **Proposed** NBCC 2015
 - Public review is completed
 - All Ballots are completed (seismic changes – late approval)
- NBCC is not official until it is published
- **Some equations / figures copied for reference only (do not use – wait for official code) – still editorial changes and final printing to happen!**
- Once published provinces then choose if and when to adopt
- 2015 NBCC – publically available Nov / Dec 2015
- See SEABC for position on State of the Art!

Overview – NBCC 2015

- **NBCC**

- National model code upon which provinces adopt or develop provincial codes with local requirements
- Consensus document
- Standing committees Part 3 to 9
- Standing committees include
 - Balance of Regulatory Officials, Industry, General Interest

- **NBCC Part 4**

- SCSD - Standing Committee on Structural Design
- SCED – Standing Committee on EQ Design (previously CANCEE)

Overview – NBCC 2015

Volume 1 - Division A

- **Compliance** - Div. B (Code Solution) or Alternative Solution
- **Definitions** (*Italicized Words*)
- **Objective Statements** (Limit unacceptable risk of failure or serviceability)
 - OS2 – Structural Safety
 - OP2 – Structural Sufficiency of the Building
- **Functional Statements** (Specific to meet objective)
 - F20 – F23 and F8 (Main Ones)
 - E.g.. F20 – To support and withstand expected loads and forces

Overview – NBCC 2015

Volume 1 - Division C – Administrative Provisions

- Application – Section 2.1
- Administration (Drawings, Calculations) – Section 2.2
- Alternative Solutions – Section 2.3

Overview – NBCC 2015

Volume 2 - Division B – Acceptable Solutions

- Simply follow code requirements - Part 1 to 9
- For structural forms the basis of most work we perform.
- Includes climactic data (Appendix C)
- Occasionally we need to use Alternative Solutions – Go back to A and C and ensure O and F for Part B are met.
 - » E.g. – CLT

Users Guide – Part 4

- Commentaries on Part 4 of Division B

Overview of Major Changes – NBCC 2015

1. Limit States Design - Companion Load Combinations
2. Live Loads – Guards
3. Climatic Data (Table C-2, Appendix C)
4. Snow Loads
5. Wind Loads
6. Design Basis for Glass

Two other topics for Discussion

7. Fire – Rare Load Case (Commentary)
8. Administrative Provisions – Drawing Requirements
 - Primary vs Non Structural
 - SER / SRP / Specialty Engineer

Overview of Major Changes – NBCC 2015

1. **Limit States Design - Companion Load Factors**
2. Live Loads - Guards
3. Climatic Data (Table C-2, Appendix C)
4. Snow Loads
5. Wind Loads
6. Design Basis for Glass
7. Fire – Rare Load Case (Commentary)
8. Administrative Provisions – Drawing Requirements

Limit States Design– Companion Factors

- Revised Combination for Snow and Live Load
 - Companion Load increased from 0.5 to 1 for both Live (L) or Snow (S) when both L and S are considered together
 - Companion Load factor for L or Lx (cranes) to be increased by 0.5 for storage areas, equipment areas, and service rooms

Table 4.3.1.2 a – Load Combinations Without Crane Loads for Ultimate Limit States

Case	Load Combination ⁽¹⁾	
	Principal Loads	Companion Loads
1	1.4D ⁽²⁾	—
2	(1.25D ⁽³⁾ or 0.9D ⁽⁴⁾) + 1.5L ⁽⁵⁾	0.5 1.0S ⁽⁶⁾ or 0.4W
3	(1.25D ⁽³⁾ or 0.9D ⁽⁴⁾) + 1.5S	0.5 1.0L ⁽⁶⁾ ⁽⁷⁾ or 0.4W
4	(1.25D ⁽³⁾ or 0.9D ⁽⁴⁾) + 1.4W	0.5L ⁽⁷⁾ or 0.5S
5	1.0D ⁽⁴⁾ + 1.0E ⁽⁸⁾	0.5L ⁽⁶⁾ ⁽⁷⁾ + 0.25S ⁽⁶⁾

Limit States Design– Companion Factors

Table 4.1.3.2.B.
Load Combinations With Crane Loads for Ultimate Limit States
 Forming Part of Sentences 4.1.3.2.(2), (5) to (8), and (10)

Case	Load Combination ⁽¹⁾	
	Principal Loads	Companion Loads
1	$(1.25D^{(2)} \text{ or } 0.9D^{(3)}) + (1.5C + 1.0L_{XC})$	$1.0S^{(4)} \text{ or } 0.4W$
2	$(1.25D^{(2)} \text{ or } 0.9D^{(3)}) + (1.5L_{XC}^{(5)} + 1.0C)$	0.5 $1.0S^{(4)}$ or $0.4W$
3	$(1.25D^{(2)} \text{ or } 0.9D^{(3)}) + 1.5S$	$(1.0C + \del{0.5}1.0L_{XC}^{(4) (6)})$
4	$(1.25D^{(2)} \text{ or } 0.9D^{(3)}) + 1.4W$	$(1.0C^{(7)} + 0.5L_{XC}^{(4) (6)})$
5	$(1.25D^{(2)} \text{ or } 0.9D^{(3)}) + C_7$	—
6	$1.0D^{(3)} + 1.0E^{(8)}$	$1.0C_d + 0.5L_{XC}^{(4) (6)} + 0.25S^{(4)}$

Overview of Major Changes – NBCC 2015

1. Limit States Design - Companion Load Factors
- 2. Live Loads - Guards**
3. Climatic Data (Table C-2, Appendix C)
4. Snow Loads
5. Wind Loads
6. Design Basis for Glass
7. Fire – Rare Load Case (Commentary)
8. Administrative Provisions – Drawing Requirements

Live Loads – Guards 4.1.5.14

- Inward load reduced to 50% of outward load
- Size of opening between vertical elements within guard not to exceed part 3 limits when 2 adjacent elements are each subject to a live load of 0.1 kN in opposite directions
- Loads on walls acting as guards – only outward forces required



Overview of Major Changes – NBCC 2015

1. Limit States Design - Companion Load Factors
2. Live Loads - Guards
3. **Climatic Data (Table C-2, Appendix C)**
4. Snow Loads
5. Wind Loads
6. Design Basis for Glass
7. Fire – Rare Load Case (Commentary)
8. Administrative Provisions – Drawing Requirements

Climactic Loads – Table C2

- Ground snow S_s updated
 - Including data up to 2012
 - Interpolation between stations
 - Accounting for elevations
- 600 locations in Canada
 - 84% remain unchanged
 - 11% of locations increased
 - 4% decreased
 - Greatest proportion of increases Yukon, NWT, Nunavut
 - Significant increases in BC
 - Powel River – from 1 to 1.7 kPa
 - Revelstoke – from 5.8 to 7.2 kPa



Overview of Major Changes – NBCC 2015

1. Limit States Design - Companion Load Factors
2. Live Loads - Guards
3. Climatic Data (Table C-2, Appendix C)
4. **Snow Loads**
5. Wind Loads
6. Design Basis for Glass
7. Fire – Rare Load Case (Commentary)
8. Administrative Provisions – Drawing Requirements

Snow Loads – Clause 4.1.6

- Significant rewrite – Incorporating most commentary snow requirements / diagrams

- Equation for C_b revised

$$C_b = 0.8 \quad \text{for } l_c \leq \left(\frac{70}{C_w^2}\right) \text{m, and}$$

$$C_b = \frac{1}{C_w} \left[1 - (1 - 0.8C_w) \exp\left(-\frac{l_c C_w^2 - 70}{100}\right) \right] \quad \text{for } l_c > \left(\frac{70}{C_w^2}\right) \text{m}$$

- Table for C_b provided for values of $l_c C_w^2$

Table 4.1.6.2.B.
Basic Roof Snow Load Factor for $l_c > (70/C_w^2)$

Value of $l_c \cdot C_w^2$	Value		
	1.0	0.75	0.5
70	0.80	0.80	0.80
80	0.82	0.85	0.91
100	0.85	0.94	1.11
120	0.88	1.01	1.27
140	0.90	1.07	1.40
160	0.92	1.12	1.51
180	0.93	1.16	1.60
200	0.95	1.19	1.67
240	0.96	1.21	1.73
280	0.96	1.24	1.78

- Commentary figure provided

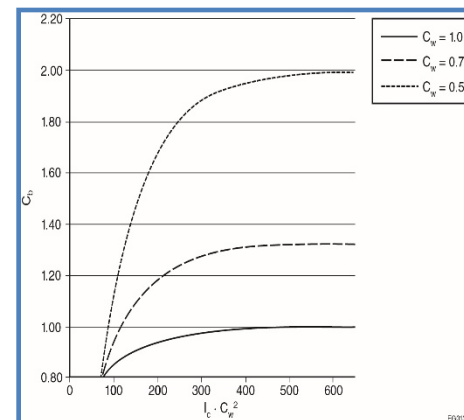

Snow Loads – Clause 4.1.6.5 – Multi Level Roofs

- Significant portions of commentary moved into main code with minor revisions to equations
- C_{a0} Includes β Term for Load cases where $\beta = 1.0$ for Case I, and 0.67 for Cases II and III,
- 3 drift cases now need be considered based on source area and corresponding characteristic length

$$C_{a0} = \beta \frac{\gamma h}{C_b S_s}$$

and

$$C_{a0} = \frac{F}{C_b}$$

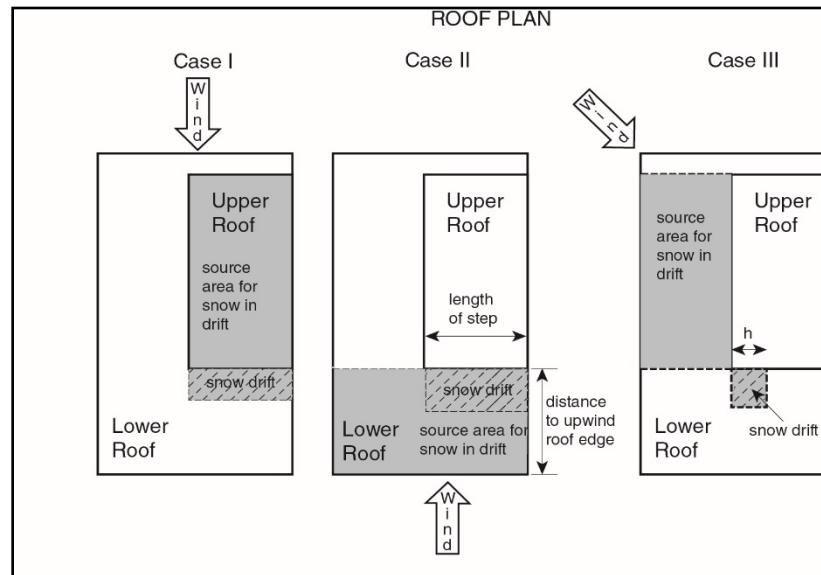
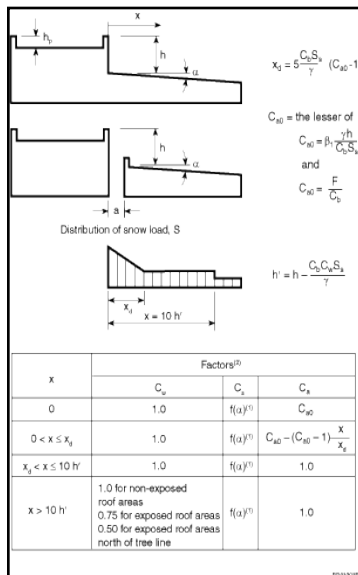

See commentary for worked example

Snow Loads – Clause 4.1.6.6 – Horizontal Gap

- Clause covers the drifting caused by a high roof adjacent a low roof separated by a gap
- If gap > 5 m – no consideration required
- If gap < 5m – refer to clause 4.1.6.5
- Need to consider β for case 1 and 2 (see commentary)

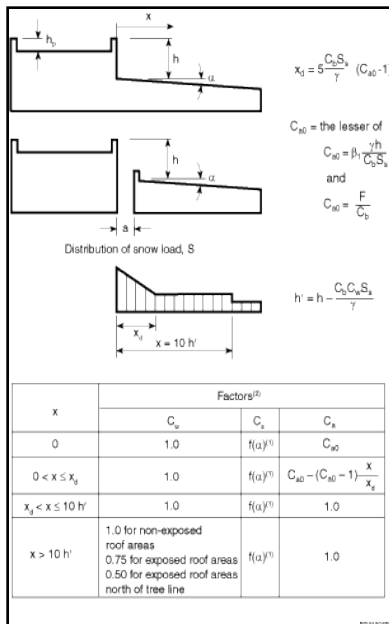

Snow Loads – Additional Clauses

- Clause 4.1.6.7 – Areas Adjacent to Roof Projections moved from commentary
- Clause 4.1.6.8 – Snow Drift At Corners

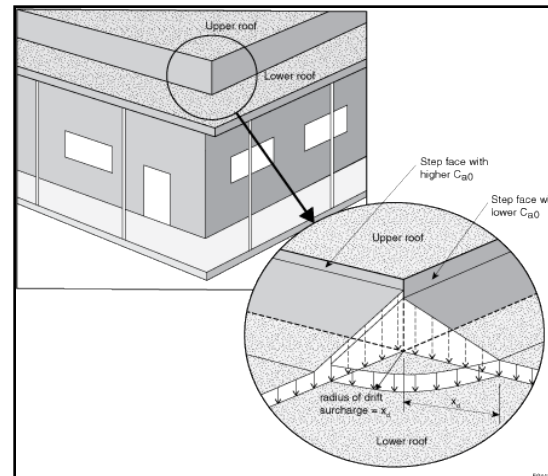
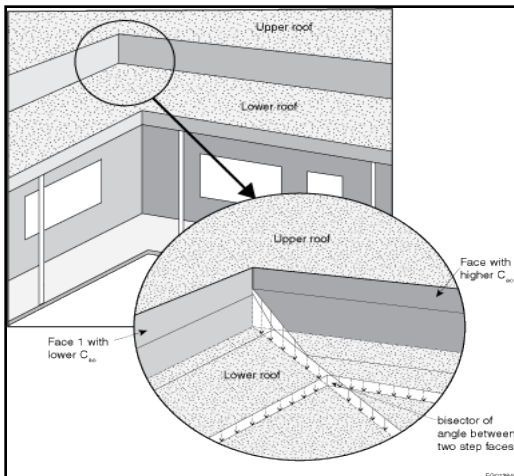
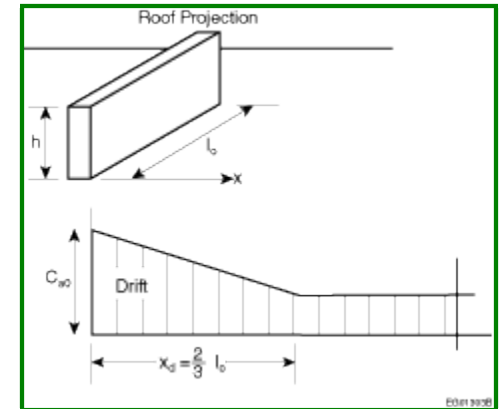

Snow Loads – Additional Clauses

- **Clause 4.1.6.9 – Gable Roofs**

- Code Language Provided to describe loading with some rearrangement of equations
- Commentary includes figure

- **Clause 4.1.6.10 – Arched Roof, Curved Roofs and Domes**

- Moved from commentary
- Some revisions to simplify equations
- Additional figures for domes added

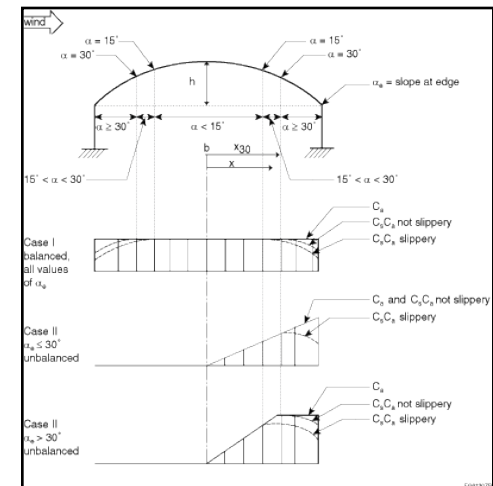
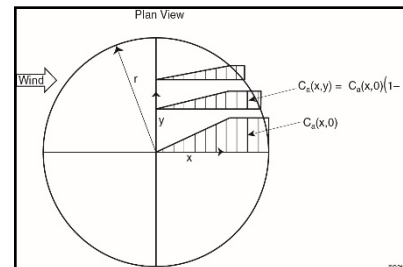
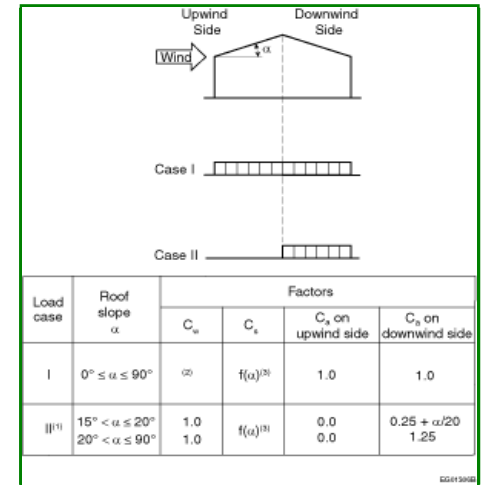

Snow Loads – Additional Clauses

- Clause 4.1.6.11 – Snow Loads due to Sliding

- Moved from commentary
- Need to consider for
 - Greater than 0° for Slippery Roof
 - Greater than 20° for non slippery roof

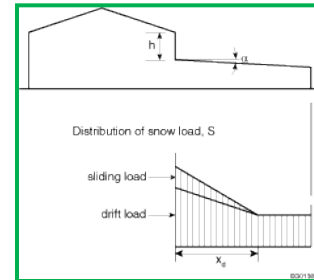

- Clause 4.1.6.12 – Valleys in Curved or Sloped Roofs

- Moved from commentary

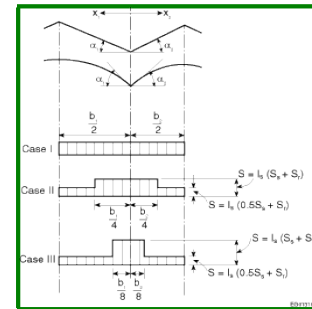

Snow Loads – Additional Clauses

- **Clause 4.1.6.13 – Specific Weight of Snow γ**

Where γ , shall be taken as the lesser of:

4.0 kN/m³ or

0.43S_s + 2.2 kN/m³

$\gamma = 3$ kN/m³ at S_s = 1.86 kPa

$\gamma = 4$ kN/m³ at S_s = 4.19 kPa

- **Clause 4.1.6.14 – Snow Removal**

- Can not rely on as rational basis to reduce loads

- **Clause 4.1.6.15 – Ice Loading of Structures**

- Follow CSA S37

Overview of Major Changes – NBCC 2015

1. Limit States Design - Companion Load Factors
2. Live Loads - Guards
3. Climatic Data (Table C-2, Appendix C)
4. Snow Loads
- 5. Wind Loads**
6. Design Basis for Glass
7. Fire – Rare Load Case (Commentary)
8. Administrative Provisions – Drawing Requirements

Wind Loads – Clause 4.1.7

- Significant rewrite – Incorporating most commentary wind requirements / diagrams
- Clause 4.1.7.1 - Specified Wind Loads

Where Static (S), Dynamic (D) or Wind Tunnel (WT) is required

1. Buildings not dynamically sensitive – S, D, WT
 2. Buildings dynamically sensitive – D, WT
 3. Buildings sensitive to wake buffeting or channeling or very dynamically sensitive – WT
- 4.1.7.1 (6) - Computational Fluid Dynamics
 - Not allowed for under the code –
 - No standards cover
 - Not possible to verify the reliability or accuracy

Wind Loads – Clause 4.1.7

- 4.7.2 – Classifications of Buildings - Summary

1. Buildings Not Dynamically Sensitive

- Except as provided in sentence 2 and 3

2. Buildings Considered Dynamically Sensitive if

- Frequency f - $1\text{hz} > f > .25\text{hz}$ (period between 1 to 4 s)
- $H > 60\text{m}$
- $H > 4 \times w$ where w = effective width

3. Buildings Sensitive to Wake Buffeting or Channeling or Very Dynamically Sensitive if

- Frequency f – $f < .25\text{hz}$ (period $> 4\text{s}$)
- $H > 6 \times w$ where w = effective width (new requirement)

Wind Loads – Clause 4.1.7

- 4.1.7.3 – Static Procedure

- Equations revised to include C_t (topographical effect)

$$p = I_w q C_e C_t C_s C_p \quad p_i = I_w q C_{ei} C_t C_{si} C_{pi}$$

- Clause 4.1.7.3 (6) - Reference height h
 - defined for external and internal pressures (4.1.7.3 (6))

Wind Loads – Clause 4.1.7

- 4.1.7.4 – Topographic Factor
 - Commentary moved into code.
 - Includes Ct factor (2010 used a modified Ce)

$$C_t = \left(1 + \frac{\Delta S}{C_s}\right)(1 + \Delta S)$$

$$\Delta S = \Delta S_{\max} \left(1 - \frac{|x|}{kL_h}\right) e^{-\alpha z/L}$$

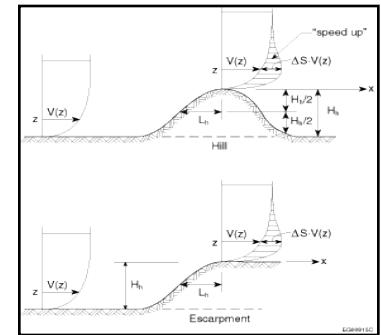

Shape of Hill or Escarpment	ΔS_{\max} (1)	α	k	
			x < 0	x ≥ 0
2-dimensional hill	2.2 H _h /L _h	3	1.5	1.5
2-dimensional escarpment	1.3 H _h /L _h	2.5	1.5	4
3-dimensional axi-symmetrical hill	1.6 H _h /L _h	4	1.5	1.5

Wind Loads – Clause 4.1.7

- 4.1.7.5 – External Pressure Coefficients (Buildings of all Sizes)
 - Code language used to define C_p used in determining loads
 - C_p defined for overall building loads and cladding Loads
 - Clause 4.1.7.6 Alternate for certain shape of low rise buildings
 - Commentary includes figures:

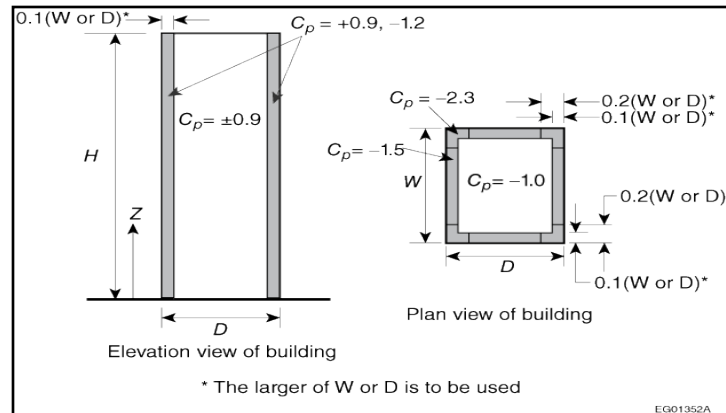
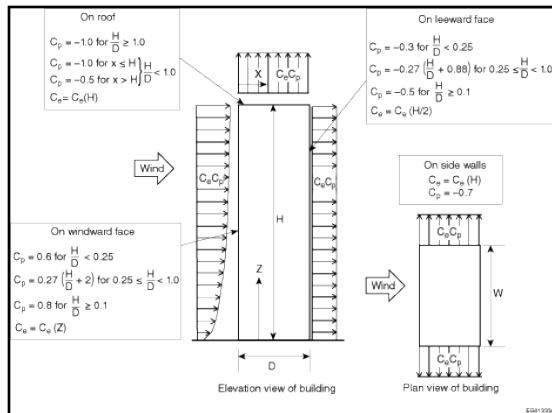

Wind Loads – Clause 4.1.7

- 4.1.7.6 – External Pressure Coefficients for Low Buildings
 - Clause 4.1.7.6 (1) – Can use for buildings with height H , that is both less than or equal to 20m and less than the smaller plan.

- Figure 4.1.7.6 A (moved from commentary – Fig I7)
 - External peak values of C_pC_g for primary structural actions arising from wind loads acting simultaneously on all surfaces of low buildings ($H < 20m$)

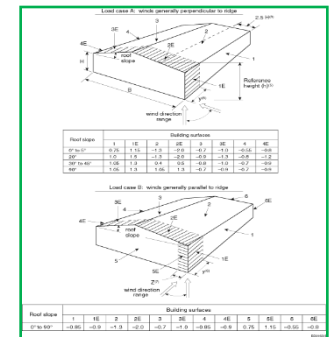

- Figure 4.1.7.6 B (moved from commentary – Fig I8)
 - External peak values of C_pC_g on individual walls for the design of cladding and secondary structural members

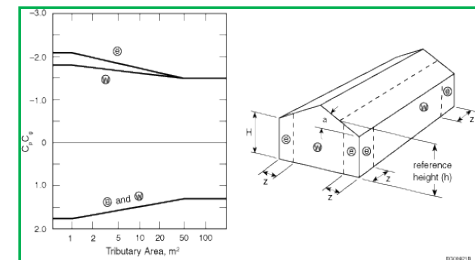

Wind Loads – Clause 4.1.7

• 4.1.7.6 – External Pressure Coefficients for Low Buildings

• Figure 4.1.7.6 C (moved from commentary – Fig I9)

- External peak values of C_pC_g on roofs with a slope of 7° or less for the design of structural components and cladding

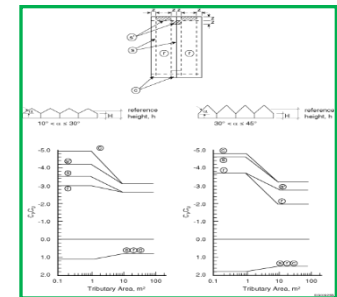

• Figure 4.1.7.6 D (moved from commentary – Fig I10)

- External peak values of C_pC_g for the design of the structural components and cladding of building with stepped roofs

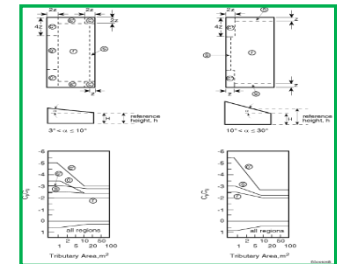

• Figure 4.1.7.6 E (moved from commentary – Fig I11)

- External peak values of C_pC_g on single-span gabled and hipped roofs with a slope greater than 7° for the design of structural components and cladding

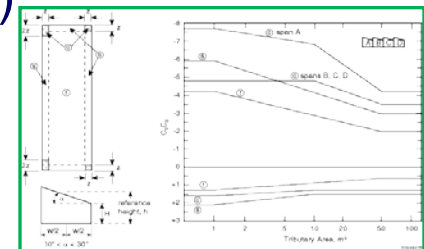

Wind Loads – Clause 4.1.7

- 4.1.7.7 – Internal Pressure Coefficient
 - Commentary table now included in the code.

<i>Building Openings</i>	<i>Values for C_{pi}</i>
Uniformly distributed small openings amounting to less than 0.1% of the total surface area	-0.15 to 0.0
Non-uniformly distributed openings of which none is significant or significant openings that are wind-resistant and closed during storms	-0.45 to +0.30
Large openings likely to remain open during storms	-0.70 to +0.70

- Figure 4.1.7.8 - Dynamic Procedure
 - Commentary procedure now moved into code.
 - Minor rearrangement of equations for C_g.

Wind Loads – Clause 4.1.7

- 4.1.7.9 – Full and Partial Loading
 - Commentary material now included in the code.
 - Code Language describe loading requirements
 - Commentary still includes Figure
- 4.1.7.10 – Interior Walls and Partitions
- 4.1.7.11 – Exterior Ornamentations, Equipment and Appendages
 - Reference to CSA S37 – Ice Buildup Commentary Procedure now moved into code.
 - Effect on Base Building – Where there are a number of similar components can use total area of all components (i.e. global lateral system)
 - Locally structure at each connection must be designed for the peak load based on the individual component



Wind Loads – Clause 4.1.7

- 4.1.7.12 – Wind Tunnel Procedures – Clauses cover
 - Referenced Standard ASCE / SEI-49
 - For design of main structure / cladding
 - When Adjacent Buildings Provide Sheltering
 - When an adjacent building provides substantial sheltering, the loads for the main structural system shall be no lower than 80% of the loads determined from tests with the effect of the sheltering removed as applied to either
 - Base Shear V when $H/w \leq 1$
 - Base Moment M when $H/w > 1$

Under Wind Tunnel Testing – Maximum Moment and Base Shear do not necessarily occur at the same time. Shorter buildings tend to be shear dominated whereas taller are moment dominated



Overview of Major Changes – NBCC 2015

1. Limit States Design - Companion Load Factors
2. Live Loads - Guards
3. Climatic Data (Table C-2, Appendix C)
4. Snow Loads
5. Wind Loads
- 6. Design Basis for Glass**
7. Fire – Rare Load Case (Commentary)
8. Administrative Provisions – Drawing Requirements

Glass Design – Clause 4.3.6

- Clause 4.3.6 now references both ASTM E1300 in addition to CGSB-12.20.
 - ASTM E1300 has been kept up to date where as CGSB not since 1989.
 - CGSB still referenced as it considers some applications not covered under ASTM
 - Requires use of adjustment factors as follows
 - CAN/CGSB-12.20-M “Structural Design of Glass for Buildings”
 - Adjustment factor on wind load W of not less than 0.75
 - ASTM E-1300 “Standard Practice for Determining Load Resistance of Glass Buildings”
 - Adjustment factor on wind load W of not less than 1.0
 - Commentary summarizes differences
 - Adjustment factored provided to create same level of reliability whether using ASTM or CGSB.

Overview of Major Changes – NBCC 2015

1. Limit States Design - Companion Load Factors
2. Live Loads - Guards
3. Climatic Data (Table C-2, Appendix C)
4. Snow Loads
5. Wind Loads
6. Design Basis for Glass
- 7. Fire – Rare Load Case (Commentary)**
8. Administrative Provisions – Drawing Requirements

Fire – Commentary A

- Load Combination for Determination of Fire Resistance
 - Not a simple load case or analysis
 - Load case is a rare event
 - Use of equation requires expert knowledge in Rational Fire Design
 - Fire resistant rating time
 - Appropriate time temperature curve (based on consumables)
 - Must account for forces on structure due to applied loads
 - Include Loads resulting from high temperature
 - Forces will result in indeterminate structures
 - Forces will result due to temperature gradient in composite floors
 - On material resistance - Need to consider the effect on material property – i.e..
 - Steel Loses Strength with Increasing Temperature
 - Wood Chars reducing net section (0.6mm to 0.8mm per min)
 - Recommended Rare Load Combination (In Commentary A)
 - $D + T_s + (\alpha L \text{ or } 0.25S)$ where $\alpha = 1.0$ for storage / equipment and service rooms
 $\alpha = 0.5$ for other occupancies
 - T_s is only = 0 for statically determinant systems



Overview of Major Changes – NBCC 2015

1. Limit States Design - Companion Load Factors
2. Live Loads - Guards
3. Climatic Data (Table C-2, Appendix C)
4. Snow Loads
5. Wind Loads
6. Design Basis for Glass
7. Fire – Rare Load Case (Commentary)
8. **Administrative Provisions – Drawing Requirements**
 - Primary vs Non Structural
 - SER / SRP / Specialty Engineer

Administrative Changes – Drawing Requirements

Volume 1 - Division C – Administrative Provisions

- Administration in NBCC state:
- Section 2.2.4 – Structural and Foundation Drawings and Calculations
 - Professional Seal Required
 - Information on Drawings
 - Name and Address of Person Responsible
 - Date of Code and Standards
 - Dimension, locations and size of all structural members in sufficient detail to enable the design to be checked
 - Sufficient detail to allow dead loads to be determined, and
 - All effects and loads, other than dead loads, used for the design of the structural members and exterior cladding.

Statement is in conflict with APEGBC Guidelines and creates some confusion. NBCC has a task group working on this for 2020

Administrative Changes – Drawing Requirements

“APEGBC Structural Guidelines

4.2.3.1 *Primary Structural System*

In conjunction with designing the *primary structural system*, the *SER* may:

- with respect to *primary structural elements*, such as connection details and proprietary products:
 - determine and specify in the *contract documents* which elements will be designed by *SRPs*;
 - specify types of elements, their positions within the structure and methods of connecting to the *primary structural system*;
 - specify loads and design criteria for use by *SRPs* in their design; and
 - review the design of *specialty structural elements* and *secondary structural elements* for conformity with the *primary structural system*.

- with respect to *non-structural elements* attached to the *primary structural system*:
 - review the effect of the elements on the *primary structural system*;
 - design the *primary structural system* to accept and support such elements; and
 - provide information regarding the supporting capability and physical attachment limitations of the *primary structural system*.

APEGBC Structural Guidelines (for discussion)

- Structural Engineer of Record (SER) - Responsibility

- Primary Structure

- SER responsible for the integrity of the primary structural system for the building
 - SER can rely on other engineers (SRP) for engineering of primary elements but still takes overall responsibility (steel joists, wood trusses, bearings, FRP)
 - SER must clearly define loads and movements that affect the specialty items.

- **Specialty Structural Element**

- Proprietary or specialty component which is part of the primary structure. Designed by a Specialty Structural Engineer who takes responsibility for design, but overall responsibility falls under SER
 - Specialty Engineer (Supporting Registered Professional –SRP) must provide a schedule S and assume responsibility for the design of the specialty component and the necessary field reviews
 - SER still maintains overall responsibility and must satisfy themselves with the design and field reviews (and conduct additional checks if warranted)

APEGBC Structural Guidelines (for discussion)

- **Structural Engineer of Record (SER) - Responsibility**
 - **Secondary Structure (or Non Structural Component)**
 - SER is responsible to design the primary structure to accommodate for the secondary elements and for their effect on the primary structure and is therefore responsible to review the shop drawings for the effect.
 - *The SER should specify the building movements for the Specialty Engineer of the Secondary or Non Structural component such that they can be accounted for in the design. (Steel Studs, Glazing, Cladding, Flag Polls, etc.)*
 - *The SER should also provide overall base building loading parameters such that the loads including dead, live, wind, seismic (and other loads) can be accounted for in the design of the element. No need to provide the loads.*
- **Specialty Engineers Responsibility** (Secondary / Non Structural Component)
 - The specialty Engineer for the secondary structure (or Non Structural component) is responsible for the design of the secondary element including developing the loads for that element and ensuring it works within any movement criteria provided by the SER. (cladding, glazing, flag pole, awning)

Suggested Information on Drawings by SER

(for discussion)

- **The SER needs to satisfy**

- APEGBC Guidelines
- BCBC Administrative Provisions (Based on NBCC)

- **To do this - The SER needs to provide**

1. Building Movements for the Primary Structure (??)
2. Loading Information
 - For the design of the Primary and specialty structure
3. Loading Parameters used for Secondary / Non Structural (??)
 - For the development of loads for the design of secondary / non structural components
 - Don't need to provide the loads!

Suggested Information on Drawings by SER

(For Discussion)

1. Building Movements for the Primary Structure (?)

- Including the anticipated building movements (vertical and horizontal) to allow for others to detail elements accordingly (for both specialty structural, and secondary / non structural components)
- Should include movements due to building loads, live loads, environmental loads, as well as creep, shrinkage, temperature etc.
- If movements are not provided – How can others detail?

Suggested Information on Drawings by SER

(For Discussion)

2. Loading Information for the Design of the Primary Structure

- All effects and loads, other than dead loads, used for the design of the structural members
- Loads used by Specialty Structural Engineer in design of Primary structure (OWSJ, Wood Trusses)
- Loads for Complex Roofs and Floors should be shown on plans (no reference back to BCBC for Specialty Engineer (SRP) to figure out)
- You need to develop the loads anyways!

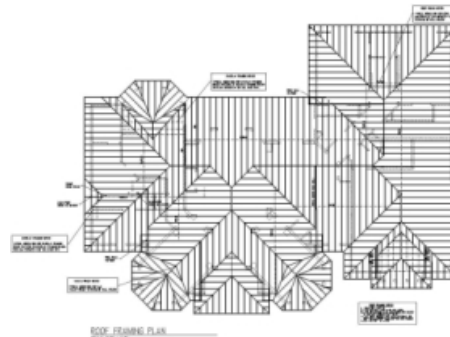

Suggested Information on Drawings by SER

(For Discussion)

3. Loading Parameters used for Secondary / Non Structural

- Provide snow loads and include on plans where loading is complex. You need to design for these loads – don't leave to interpretation.
- Provide wind and seismic parameters used for the base building
 - Seismic – I.e., R_d , R_o , $S_a(.2)$, $S_a(.5)$, $S_a(1)$, $S_a(2)$, **Site Class**
 - Wind - I_w (ULS and SLS), q_{50} , Exposure Class, C_{pi} , C_t
- Engineer for Secondary / Non Structural component is responsible for developing the loads used for the design of the element.

2015 NBCC Summary

QUESTIONS?