



**NIILM**  
University

HEALTH MEDIA  
ENGINEERING mathematics  
DESIGN management  
GEOGRAPHY EDUCATION  
ART PHYSICS  
BIOTECHNOLOGY agriculture  
CHEMISTRY history  
MECHANICS LANGUAGE  
psychology

# Metal Casting

# **CONTENT**

**CHAPTER 1- Introduction on Metal Casting**

**CHAPTER 2- Casting**

**CHAPTER 3- Sand Casting**

**CHAPTER 4 - Plaster Mold Casting**

**CHAPTER 5 - Shell Molding**

**CHAPTER 6 - Investment Casting**

**CHAPTER 7 - Evaporative Casting**

**CHAPTER 8 - Permanent Mold Casting**

**CHAPTER 9 - Die Casting**

**CHAPTER 10 - Semi-Solid Metal Casting**

**CHAPTER 11- Centrifugal Casting**

**CHAPTER 12 - Continous Casting**

# CHAPTER 1

## Introduction on Metal Casting

In metalworking, casting involves pouring liquid metal into a mold, which contains a hollow cavity of the desired shape, and then allowing it to cool and solidify. The solidified part is also known as a casting, which is ejected or broken out of the mold to complete the process. Casting is most often used for making complex shapes that would be difficult or uneconomical to make by other methods.

Molding or moulding (see spelling differences) is the process of manufacturing by shaping liquid or pliable raw material using a rigid frame called a mold or matrix. This itself may have been made using a pattern or model of the final object.

A mold or mould is a hollowed-out block that is filled with a liquid or pliable material like plastic, glass, metal, or ceramic raw materials. The liquid hardens or sets inside the mold, adopting its shape. A mold is the counterpart to a cast. The very common bi-valve molding process uses two molds, one for each half of the object. Piece-molding uses a number of different molds, each creating a section of a complicated object. This is generally only used for larger and more valuable objects.

The manufacturer who makes the molds is called the moldmaker. A release agent is typically used to make removal of the hardened/set substance from the mold easier. Typical uses for molded plastics include molded furniture, molded household goods, molded cases, and structural materials.

Casting processes have been known for thousands of years, and widely used for sculpture, especially in bronze, jewellery in precious metals, and weapons and tools. Traditional techniques include lost-wax casting, plaster mold casting and sand casting.

Metal casting is one of the most common casting processes. Metal patterns are more expensive but are more dimensionally stable and durable. Metallic patterns are used where repetitive production of castings is required in large quantities.

Casting is a 6000 year old process. The oldest surviving casting is a copper frog from 3200 BC.

The modern casting process is subdivided into two main categories: expendable and non-expendable casting. It is further broken down by the mold material, such as sand or metal, and pouring method, such as gravity, vacuum, or low pressure.

Casting is a manufacturing process by which a liquid material is usually poured into a mold, which contains a hollow cavity of the desired shape, and then allowed to solidify. The solidified part is also known as a casting, which is ejected or broken out of the mold to complete the process. Casting materials are usually metals or various cold setting materials that cure after mixing two or more components together; examples are epoxy, concrete, plaster and clay. Casting is most often used for making complex shapes that would be otherwise difficult or uneconomical to make by other methods.

**Epoxy** is the cured end product of epoxy resins, as well as a colloquial name for the epoxide functional group. Epoxy resins, also known as polyepoxides are a class of reactive prepolymers and polymers which contain epoxide groups. Epoxy resins may be reacted (cross-linked) either with themselves through catalytic homopolymerisation, or with a wide range of co-reactants including polyfunctional amines, acids (and acid anhydrides), phenols, alcohols, and thiols. These co-reactants are often referred to as hardeners or curatives, and the cross-linking reaction is commonly referred to as curing. Reaction of polyepoxides with themselves or with polyfunctional hardeners forms a thermosetting polymer, often with strong mechanical properties as well as high temperature and chemical resistance. Epoxy has a wide range of applications, including metal coatings, use in electronics / electrical components, high tension electrical insulators, fiber-reinforced plastic materials, and structural adhesives. Epoxy resin is employed to bind gutta percha in some root canal procedures.

Epoxy resins are low molecular weight pre-polymers or higher molecular weight polymers which normally contain at least two epoxide groups. The epoxide group is also sometimes referred to as a glycidyl or oxirane group.

A wide range of epoxy resins are produced industrially. The raw materials for epoxy resin production are today largely petroleum derived, although some plant derived sources are now becoming commercially available (e.g. plant derived glycerol used to make epichlorohydrin).

Epoxy resins are polymeric or semi-polymeric materials, and as such rarely exist as pure substances, since variable chain length results from the polymerisation reaction used to produce them. High purity grades can be produced for certain applications, e.g. using a distillation purification process. One downside of high purity liquid grades is their tendency to form crystalline solids due to their highly regular structure, which require melting to enable processing.

An important criterion for epoxy resins is the epoxide content. This is commonly expressed as the epoxide number, which is the number of epoxide equivalents in 1 kg of resin (Eq./kg), or as the equivalent weight, which is the weight in grams of resin containing 1 mole equivalent of epoxide (g/mol). One measure may be simply converted to another:

Equivalent weight (g/mol) = 1000 / epoxide number (Eq./kg)

## **Plaster, Concrete, Or Plastic Resin**

Plaster and other chemical setting materials such as concrete and plastic resin may be cast using single-use waste molds as noted above, multiple-use 'piece' molds, or molds made of small rigid pieces or of flexible material such as latex rubber (which is in turn supported by an exterior mold). When casting plaster or concrete, the finished product is, unlike marble, unattractive, lacking in transparency, and so it is usually painted, often in ways that give the appearance of metal or stone. Alternatively, the first layers cast may contain colored sand so as to give an appearance of stone. By casting concrete, rather than plaster, it is possible to create sculptures, fountains, or seating for outdoor use. A simulation of high-quality marble may be made using certain chemically-set plastic resins (for example epoxy or polyester) with powdered stone added for coloration, often with multiple colors worked in. The latter is a common means of making attractive washstands, washstand tops and shower stalls, with the skilled working of multiple colors resulting in simulated staining patterns as is often found in natural marble or travertine.

## **Resin Casting**

Resin casting is a method of plastic casting where a mold is filled with a liquid synthetic resin, which then hardens. It is primarily used for small-scale production like industrial prototypes and

dentistry. It can be done by amateur hobbyists with little initial investment, and is used in the production of collectible toys, models and figures, as well as small-scale jewelry production.

The synthetic resin for such processes is a monomer for making a plastic thermosetting polymer. During the setting process, the liquid monomer polymerizes into the polymer, thereby hardening into a solid.

## **Process**

Most commonly a thermosetting resin is used that polymerizes by mixing with a curing agent (polymerization catalyst) at room temperature and normal pressure. The resins are named by analogy with plant resins, but are synthetic monomers for making polymer plastics. The so-called synthetic resins used include polystyrene resin, polyurethane resin, epoxy resin, unsaturated polyester resin, acrylic resin and silicone resin.

Epoxy resin has a lower viscosity than polyurethane resin; polyester resin also shrinks markedly while curing. Acrylic resin, in particular the methyl methacrylate type of synthetic resin, produces acrylic glass (also called PMMA, Lucite, Plexiglass), which is not a glass but a plastic polymer that is transparent, and very hard. It is suitable for embedding objects (such as, for example, acrylic trophies), for display purposes. Styrene is a similar liquid monomer at room temperature, which will also polymerize into clear glass-like polystyrene plastic, with addition of a suitable catalyst.

A flexible mold can be made of latex rubber, room temperature vulcanized silicone rubber or other similar materials at relatively low cost, but can only be used for a limited number of castings.

The simplest method is gravity casting where the resin is poured into the mold and pulled down into all the parts by gravity. When the two part resin is mixed air bubbles tend to be introduced into the liquid which can be removed in a vacuum chamber. The casting can also be done in a vacuum chamber (when using open molds) to either extract these bubbles, or in a pressure pot, to reduce their size to the point where they aren't visible. Pressure and/or centrifugal force can be used to help push the liquid resin into all details of the mold. The mold can also be vibrated to expel bubbles.

Each unit requires some amount of hands-on labor, making the final cost per unit produced fairly high. This is in contrast to injection molding where the initial cost of creating the metal mold is higher, but the mold can be used to produce a much higher number of units, resulting in a lower cost per unit.

## **Collectibles And Models**

Resin casting is used to produce collectible and customized toys and figures like designer toys, garage kits and ball-jointed dolls, as well as scale models, either individual parts or entire models of objects like trains, aircraft or ships. They are generally produced in small quantities, from the tens to a few hundred copies, compared to injection-molded plastic figures which are produced in many thousands. Resin casting is more labor intensive than injection molding, and the soft molds used are worn down by each cast. The low initial investment cost of resin casting means that individual hobbyists can produce small runs for their own use, such as customization, while companies can use it to produce small runs for public sale.

The creation of a toy or figure start with the traditional sculpting process where the artist designs a clay sculpture. Where appropriate, for example when making a garage kit, the sculpture is dissected into several parts like head, torso, arms and legs. A flexible mold made from room temperature vulcanized (RTV) silicone rubber is made for each part.

After the mold has been made, a synthetic resin - commonly polyurethane - mixed with a curing agent, is poured into each mold cavity. Mixing the two liquid parts causes an exothermic reaction which generates heat and within minutes causes the material to harden, yielding castings or copies in the shape of the mold into which it has been poured. The molds are commonly half-divided (like the hollowed chocolate Easter eggs with candy inside) and a release agent may be used to make removal of the hardened/set resin from the mold easier. The hardened resin casting is removed from the flexible mold and allowed to cool.

Due to aggressive nature of most compounds used for casting and the high temperature of the reaction the mold gradually degrades and loses small details. Typically, a flexible mold will yield between 25 and 100 castings depending upon the size of the part, the intensity of the heat generated.

Depending on the type of product it may then be cut or sanded to remove any casting artefacts like sprues and seams. Some products are also assembled and painted, while some models and kits, which are intended for the consumer to assemble, are left unfinished.

The ability of RTV silicone molds to reproduce even the tiniest detail means that many of these low volume castings are of very high quality. Quality of both original masters and resin castings varies due to differences in creator's skill, as well as casting techniques

## **Casting Process Simulation**

Casting process simulation uses numerical methods to calculate cast component quality considering mold filling, solidification and cooling, and provides a quantitative prediction of casting mechanical properties, thermal stresses and distortion. Simulation accurately describes a cast component's quality up-front before production starts. The casting rigging can be designed with respect to the required component properties. This has benefits beyond a reduction in pre-production sampling, as the precise layout of the complete casting system also leads to energy, material, and tooling savings.

The software supports the user in component design, the determination of melting practice and casting methoding through to pattern and mold making, heat treatment, and finishing. This saves costs along the entire casting manufacturing route.

Casting process simulation was initially developed at universities starting from the early '70s, mainly in Europe and in the U.S., and is regarded as the most important innovation in casting technology over the last 50 years. Since the late '80s, commercial programs (such as AutoCAST and MAGMA) are available which make it possible for foundries to gain new insight into what is happening inside the mold or die during the casting process.



## CHAPTER - 2

### CASTING

Casting is a solidification process, which means the solidification phenomenon controls most of the properties of the casting. Moreover, most of the casting defects occur during solidification, such as gas porosity and solidification shrinkage.

Solidification occurs in two steps: nucleation and crystal growth. In the nucleation stage solid particles form within the liquid. When these particles form their internal energy is lower than the surrounded liquid, which creates an energy interface between the two. The formation of the surface at this interface requires energy, so as nucleation occurs the material actually undercools, that is it cools below its freezing temperature, because of the extra energy required to form the interface surfaces. It then recalcensces, or heats back up to its freezing temperature, for the crystal growth stage. Note that nucleation occurs on a pre-existing solid surface, because not as much energy is required for a partial interface surface, as is for a complete spherical interface surface. This can be advantageous because fine-grained castings possess better properties than coarse-grained castings. A fine grain structure can be induced by grain refinement or inoculation, which is the process of adding impurities to induce nucleation.

All of the nucleations represent a crystal, which grows as the heat of fusion is extracted from the liquid until there is no liquid left. The direction, rate, and type of growth can be controlled to maximize the properties of the casting. Directional solidification is when the material solidifies at one end and proceeds to solidify to the other end; this is the most ideal type of grain growth because it allows liquid material to compensate for shrinkage.

### Cooling Curves

Cooling curves are important in controlling the quality of a casting. The most important part of the cooling curve is the cooling rate which affects the microstructure and properties. Generally speaking, an area of the casting which is cooled quickly will have a fine grain structure and an area which cools slowly will have a coarse grain structure. Below is an example cooling curve of a pure metal or eutectic alloy, with defining terminology.

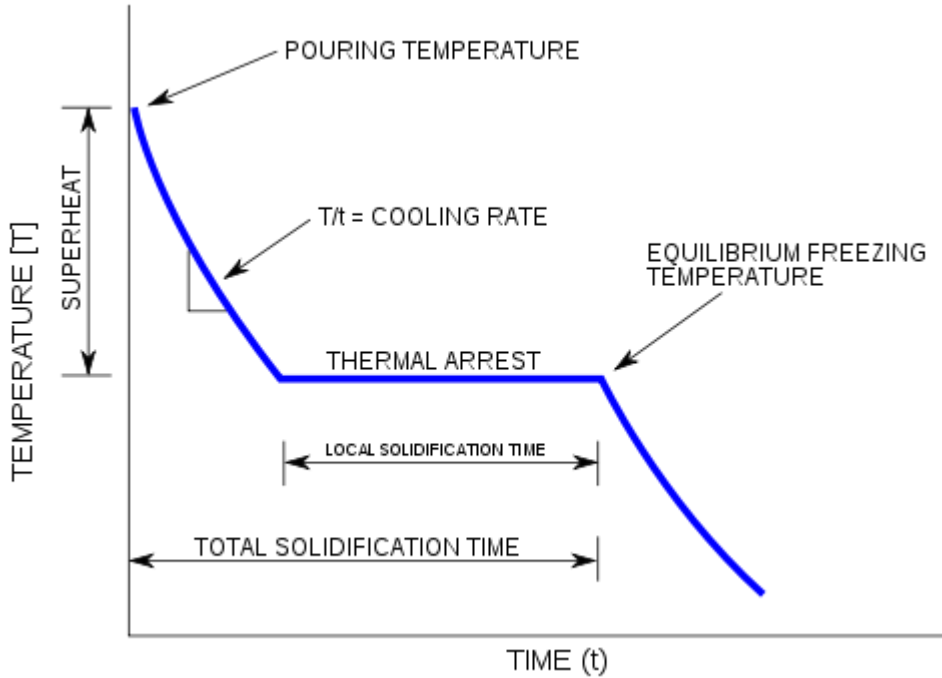

Note that before the thermal arrest the material is a liquid and after it the material is a solid; during the thermal arrest the material is converting from a liquid to a solid. Also, note that the greater the superheat the more time there is for the liquid material to flow into intricate details.

The above cooling curve depicts a basic situation with a pure alloy, however, most castings are of alloys, which have a cooling curve shaped as shown below.

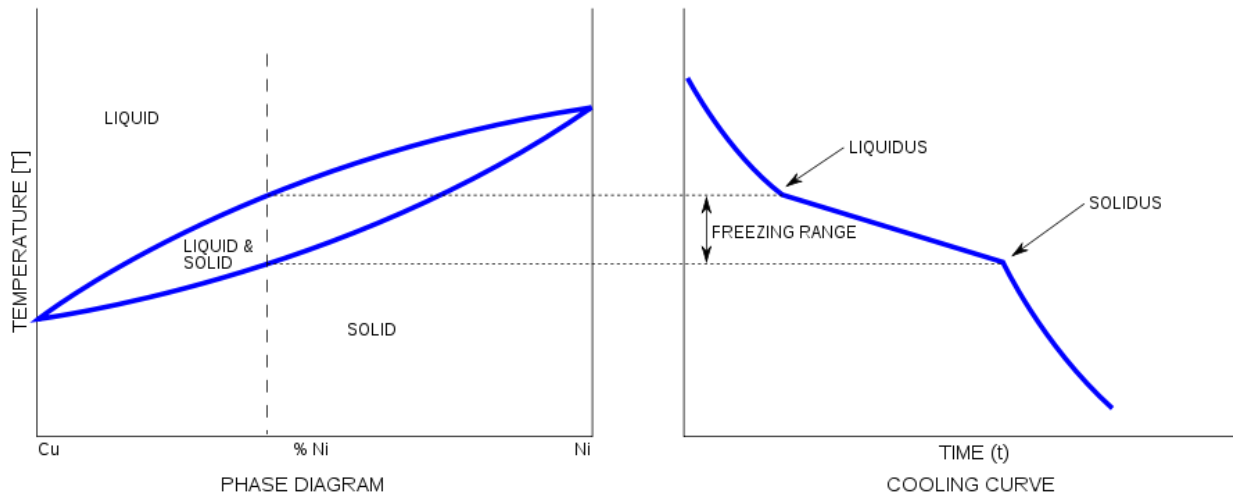

Note that there is no longer a thermal arrest, instead there is a freezing range. The freezing range corresponds directly to the liquidus and solidus found on the phase diagram for the specific alloy.

## Chvorinov's Rule

The local solidification time can be calculated using Chvorinov's rule, which is:

$$t = B \left( \frac{V}{A} \right)^n$$

Where  $t$  is the solidification time,  $V$  is the volume of the casting,  $A$  is the surface area of the casting that contacts the mold,  $n$  is a constant, and  $B$  is the mold constant. It is most useful in determining if a riser will solidify before the casting, because if the riser does solidify first then it is worthless.

## The Gating System

The gating system serves many purposes, the most important being conveying the liquid material to the mold, but also controlling shrinkage, the speed of the liquid, turbulence, and trapping dross. The gates are usually attached to the thickest part of the casting to assist in controlling shrinkage. In especially large castings multiple gates or runners may be required to introduce metal to more than one point in the mold cavity. The speed of the material is important because if the material is traveling too slowly it can cool before completely filling, leading to misruns and cold shuts. If the material is moving too fast then the liquid material can erode the mold and contaminate the final casting. The shape and length of the gating system can also control how quickly the material cools; short round or square channels minimize heat loss.

The gating system may be designed to minimize turbulence, depending on the material being cast. For example, steel, cast iron, and most copper alloys are turbulent insensitive, but aluminium and magnesium alloys are turbulent sensitive. The turbulent insensitive materials usually have a short and open gating system to fill the mold as quickly as possible. However, for turbulent sensitive materials short sprues are used to minimize the distance the material must fall when entering the mold. Rectangular pouring cups and tapered sprues are used to prevent the formation of a vortex as the material flows into the mold; these vortices tend to suck gas and oxides into the mold. A large sprue well is used to dissipate the kinetic energy of the liquid material as it falls down the sprue, decreasing turbulence. The choke, which is the smallest cross-sectional area in the gating system used to control flow, can be placed near the sprue well to slow down and smooth out the flow. Note that on some molds the choke is still placed on the gates to

make separation of the part easier, but induces extreme turbulence. The gates are usually attached to the bottom of the casting to minimize turbulence and splashing.

The gating system may also be designed to trap dross. One method is to take advantage of the fact that some dross has a lower density than the base material so it floats to the top of the gating system. Therefore long flat runners with gates that exit from the bottom of the runners can trap dross in the runners; note that long flat runners will cool the material more rapidly than round or square runners. For materials where the dross is a similar density to the base material, such as aluminium, runner extensions and runner wells can be advantageous. These take advantage of the fact that the dross is usually located at the beginning of the pour, therefore the runner is extended past the last gate(s) and the contaminates are contained in the wells. Screens or filters may also be used to trap contaminates.

It is important to keep the size of the gating system small, because it all must be cut from the casting and remelted to be reused. The efficiency, or yield, of a casting system can be calculated by dividing the weight of the casting by the weight of the metal poured. Therefore, the higher the number the more efficient the gating system/risers.

## **Shrinkage**

There are three types of shrinkage: shrinkage of the liquid, solidification shrinkage and patternmaker's shrinkage. The shrinkage of the liquid is rarely a problem because more material is flowing into the mold behind it. Solidification shrinkage occurs because metals are less dense as a liquid than a solid, so during solidification the metal density dramatically increases. Patternmaker's shrinkage refers to the shrinkage that occurs when the material is cooled from the solidification temperature to room temperature, which occurs due to thermal contraction.

## **Solidification Shrinkage**

Most materials shrink as they solidify, but, as the table to the right shows, a few materials do not, such as gray cast iron. For the materials that do shrink upon solidification the type of shrinkage depends on how wide the freezing range is for the material. For materials with a narrow freezing range, less than 50 °C (122 °F), a cavity, known as a pipe, forms in the center of the casting, because the outer shell freezes first and progressively solidifies to the center. Pure and eutectic

metals usually have narrow solidification ranges. These materials tend to form a skin in open air molds, therefore they are known as skin forming alloys. For materials with a wide freezing range, greater than 110 °C (230 °F), much more of the casting occupies the mushy or slushy zone (the temperature range between the solidus and the liquidus), which leads to small pockets of liquid trapped throughout and ultimately porosity. These castings tend to have poor ductility, toughness, and fatigue resistance. Moreover, for these types of materials to be fluid-tight a secondary operation is required to impregnate the casting with a lower melting point metal or resin.

For the materials that have narrow solidification ranges pipes can be overcome by designing the casting to promote directional solidification, which means the casting freezes first at the point farthest from the gate, then progressively solidifies towards the gate. This allows a continuous feed of liquid material to be present at the point of solidification to compensate for the shrinkage. Note that there is still a shrinkage void where the final material solidifies, but if designed properly this will be in the gating system or riser.

### **Risers And Riser Aids**

Risers, also known as feeders, are the most common way of providing directional solidification. It supplies liquid metal to the solidifying casting to compensate for solidification shrinkage. For a riser to work properly the riser must solidify after the casting, otherwise it cannot supply liquid metal to shrinkage within the casting. Risers add cost to the casting because it lowers the yield of each casting; i.e. more metal is lost as scrap for each casting. Another way to promote directional solidification is by adding chills to the mold. A chill is any material which will conduct heat away from the casting more rapidly than the material used for molding.

Risers are classified by three criteria. The first is if the riser is open to the atmosphere, if it is then it's called an open riser, otherwise it's known as a blind type. The second criterion is where the riser is located; if it is located on the casting then it is known as a top riser and if it is located next to the casting it is known as a side riser. Finally, if a riser is located on the gating system so that it fills after the molding cavity, it is known as a live riser or hot riser, but if the riser fills with materials that's already flowed through the molding cavity it is known as a dead riser or cold riser.

Riser aids are items used to assist risers in creating directional solidification or reducing the number of risers required. One of these items are chills which accelerate cooling in a certain part of the mold. There are two types: external and internal chills. External chills are masses of high-heat-capacity and high-thermal-conductivity material that are placed on an edge of the molding cavity. Internal chills are pieces of the same metal that is being poured, which are placed inside the mold cavity and become part of the casting. Insulating sleeves and toppings may also be installed around the riser cavity to slow the solidification of the riser. Heater coils may also be installed around or above the riser cavity to slow solidification.

### **Patternmaker's shrink**

Shrinkage after solidification can be dealt with by using an oversized pattern designed specifically for the alloy used. Contraction rules, or shrink rules, are used to make the patterns oversized to compensate for this type of shrinkage. These rulers are up to 2.5% oversize, depending on the material being cast. These rulers are mainly referred to by their percentage change. A pattern made to match an existing part would be made as follows: First, the existing part would be measured using a standard ruler, then when constructing the pattern, the pattern maker would use a contraction rule, ensuring that the casting would contract to the correct size.

Note that patternmaker's shrinkage does not take phase change transformations into account. For example, eutectic reactions, martensitic reactions, and graphitization can cause expansions or contractions.

### **Mold cavity**

The mold cavity of a casting does not reflect the exact dimensions of the finished part due to a number of reasons. These modifications to the mold cavity are known as allowances and account for patternmaker's shrinkage, draft, machining, and distortion. In non-expendable processes, these allowances are imparted directly into the permanent mold, but in expendable mold processes they are imparted into the patterns, which later form the mold cavity. Note that for non-expendable molds an allowance is required for the dimensional change of the mold due to heating to operating temperatures.

For surfaces of the casting that are perpendicular to the parting line of the mold a draft must be included. This is so that the casting can be released in non-expendable processes or the pattern

can be released from the mold without destroying the mold in expendable processes. The required draft angle depends on the size and shape of the feature, the depth of the mold cavity, how the part or pattern is being removed from the mold, the pattern or part material, the mold material, and the process type. Usually the draft is not less than 1%.

The machining allowance varies drastically from one process to another. Sand castings generally have a rough surface finish, therefore need a greater machining allowance, whereas die casting has a very fine surface finish, which may not need any machining tolerance. Also, the draft may provide enough of a machining allowance to begin with.

The distortion allowance is only necessary for certain geometries. For instance, U-shaped castings will tend to distort with the legs splaying outward, because the base of the shape can contract while the legs are constrained by the mold. This can be overcome by designing the mold cavity to slope the leg inward to begin with. Also, long horizontal sections tend to sag in the middle if ribs are not incorporated, so a distortion allowance may be required.

Cores may be used in expendable mold processes to produce internal features. The core can be of metal but it is usually done in sand.

## **CHAPTER – 3**

### **Sand Casting**

Sand casting, also known as sand molded casting, is a metal casting process characterized by using sand as the mold material. The term "sand casting" can also refer to an object produced via the sand casting process. Sand castings are produced in specialized factories called foundries. Over 70% of all metal castings are produced via a sand casting process.

Sand casting is relatively cheap and sufficiently refractory even for steel foundry use. In addition to the sand, a suitable bonding agent (usually clay) is mixed or occurs with the sand. The mixture is moistened, typically with water, but sometimes with other substances, to develop strength and plasticity of the clay and to make the aggregate suitable for molding. The sand is typically contained in a system of frames or mold boxes known as a flask. The mold cavities and gate

system are created by compacting the sand around models, or patterns, or carved directly into the sand.

## Basic Process

There are six steps in this process:

1. Place a pattern in sand to create a mold.
2. Incorporate the pattern and sand in a gating system.
3. Remove the pattern.
4. Fill the mold cavity with molten metal.
5. Allow the metal to cool.
6. Break away the sand mold and remove the casting.

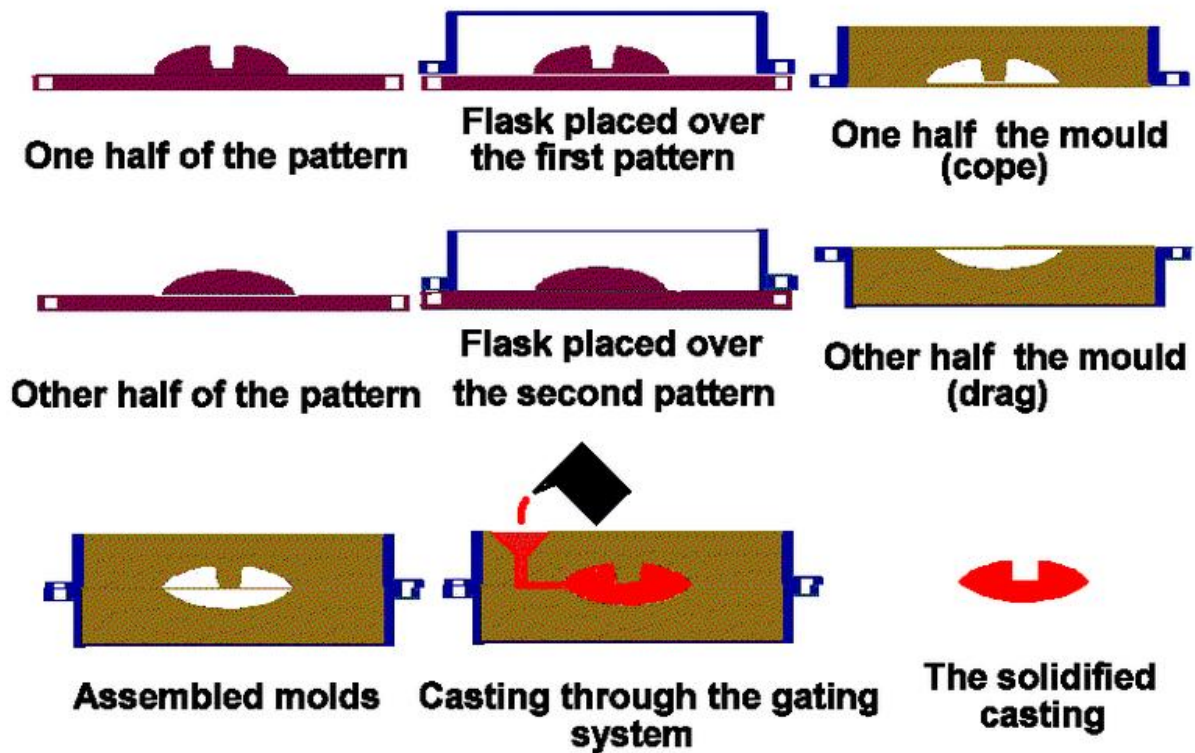



## **Components**

### **Patterns**

From the design, provided by an engineer or designer, a skilled pattern maker builds a pattern of the object to be produced, using wood, metal, or a plastic such as expanded polystyrene. Sand can be ground, swept or strickled into shape. The metal to be cast will contract during solidification, and this may be non-uniform due to uneven cooling. Therefore, the pattern must be slightly larger than the finished product, a difference known as contraction allowance. Pattern-makers are able to produce suitable patterns using "Contraction rules" (these are sometimes called "shrink allowance rulers" where the ruled markings are deliberately made to a larger spacing according to the percentage of extra length needed). Different scaled rules are used for different metals, because each metal and alloy contracts by an amount distinct from all others. Patterns also have core prints that create registers within the molds into which are placed sand cores. Such cores, sometimes reinforced by wires, are used to create under-cut profiles and cavities which cannot be molded with the cope and drag, such as the interior passages of valves or cooling passages in engine blocks.

Paths for the entrance of metal into the mold cavity constitute the runner system and include the sprue, various feeders which maintain a good metal 'feed', and in-gates which attach the runner system to the casting cavity. Gas and steam generated during casting exit through the permeable sand or via risers, which are added either in the pattern itself, or as separate pieces.

### **Molding Box And Materials**

A multi-part molding box (known as a casting flask, the top and bottom halves of which are known respectively as the cope and drag) is prepared to receive the pattern. Molding boxes are made in segments that may be latched to each other and to end closures. For a simple object—flat on one side—the lower portion of the box, closed at the bottom, will be filled with a molding sand. The sand is packed in through a vibratory process called ramming, and in this case, periodically screeded level. The surface of the sand may then be stabilized with a sizing compound. The pattern is placed on the sand and another molding box segment is added. Additional sand is rammed over and around the pattern. Finally a cover is placed on the box and it is turned and unlatched, so that the halves of the mold may be parted and the pattern with its

sprue and vent patterns removed. Additional sizing may be added and any defects introduced by the removal of the pattern are corrected. The box is closed again. This forms a "green" mold which must be dried to receive the hot metal. If the mold is not sufficiently dried a steam explosion can occur that can throw molten metal about. In some cases, the sand may be oiled instead of moistened, which makes possible casting without waiting for the sand to dry. Sand may also be bonded by chemical binders, such as furane resins or amine-hardened resins.

## **Chills**

To control the solidification structure of the metal, it is possible to place metal plates, chills, in the mold. The associated rapid local cooling will form a finer-grained structure and may form a somewhat harder metal at these locations. In ferrous castings, the effect is similar to quenching metals in forge work. The inner diameter of an engine cylinder is made hard by a chilling core. In other metals, chills may be used to promote directional solidification of the casting. In controlling the way a casting freezes, it is possible to prevent internal voids or porosity inside castings.

## **Cores**

To produce cavities within the casting—such as for liquid cooling in engine blocks and cylinder heads—negative forms are used to produce *cores*. Usually sand-molded, cores are inserted into the casting box after removal of the pattern. Whenever possible, designs are made that avoid the use of cores, due to the additional set-up time and thus greater cost.

With a completed mold at the appropriate moisture content, the box containing the sand mold is then positioned for filling with molten metal—typically iron, steel, bronze, brass, aluminium, magnesium alloys, or various pot metal alloys, which often include lead, tin, and zinc. After filling with liquid metal the box is set aside until the metal is sufficiently cool to be strong. The sand is then removed revealing a rough casting that, in the case of iron or steel, may still be glowing red. When casting with metals like iron or lead, which are significantly heavier than the casting sand, the casting flask is often covered with a heavy plate to prevent a problem known as floating the mold. Floating the mold occurs when the pressure of the metal pushes the sand above the mold cavity out of shape, causing the casting to fail.

After casting, the cores are broken up by rods or shot and removed from the casting. The metal from the sprue and risers is cut from the rough casting. Various heat treatments may be applied to relieve stresses from the initial cooling and to add hardness—in the case of steel or iron, by quenching in water or oil. The casting may be further strengthened by surface compression treatment—like shot peening—that adds resistance to tensile cracking and smooths the rough surface.

## **Design Requirements**

The part to be made and its pattern must be designed to accommodate each stage of the process, as it must be possible to remove the pattern without disturbing the molding sand and to have proper locations to receive and position the cores. A slight taper, known as draft, must be used on surfaces perpendicular to the parting line, in order to be able to remove the pattern from the mold. This requirement also applies to cores, as they must be removed from the core box in which they are formed. The sprue and risers must be arranged to allow a proper flow of metal and gasses within the mold in order to avoid an incomplete casting. Should a piece of core or mold become dislodged it may be embedded in the final casting, forming a sand pit, which may render the casting unusable. Gas pockets can cause internal voids. These may be immediately visible or may only be revealed after extensive machining has been performed. For critical applications, or where the cost of wasted effort is a factor, non-destructive testing methods may be applied before further work is performed.

## **Process**

In general, we can distinguish between two methods of sand casting; the first one using green sand and the second being the air set method.

## **Green Sand**

These expendable molds are made of wet sands that are used to make the mold's shape. The name comes from the fact that wet sands are used in the molding process. Green sand is not green in color, but "green" in the sense that it is used in a wet state (akin to green wood). Unlike the name suggests, "green sand" is not a type of sand on its own, but is rather a mixture of:

silica sand ( $\text{SiO}_2$ ), or chromite sand ( $\text{FeCr}_2\text{O}$ ), or zircon sand ( $\text{ZrSiO}_4$ ), 75 to 85%, or olivine, or staurolite, or graphite.

bentonite (clay), 5 to 11%

water, 2 to 4%

inert sludge 3 to 5%

anthracite (0 to 1%)

There are many recipes for the proportion of clay, but they all strike different balances between moldability, surface finish, and ability of the hot molten metal to degas. The coal, typically referred to in foundries as sea-coal, which is present at a ratio of less than 5%, partially combusts in the presence of the molten metal leading to offgassing of organic vapors. Green Sand for non-ferrous metals do not use coal additives since the CO created is not effective to prevent oxidation. Green Sand for aluminum typically uses olivine sand (a mixture of the minerals forsterite and fayalite which are made by crushing dunite rock). The choice of sand has a lot to do with the temperature that the metal is poured. At the temperatures that copper and iron are poured, the clay gets inactivated by the heat in that the montmorillonite is converted to illite, which is a non-expanding clay. Most foundries do not have the very expensive equipment to remove the burned out clay and substitute new clay, so instead, those that pour iron typically work with silica sand that is inexpensive compared to the other sands. As the clay is burned out, newly mixed sand is added and some of the old sand is discarded or recycled into other uses. Silica is the least desirable of the sands since metamorphic grains of silica sand have a tendency to explode to form sub-micron sized particles when thermally shocked during pouring of the molds. These particles enter the air of the work area and can lead to silicosis in the workers. Iron foundries spend a considerable effort on aggressive dust collection to capture this fine silica. The sand also has the dimensional instability associated with the conversion of quartz from alpha quartz to beta quartz at 1250 degrees F. Often additives such as wood flour are added to create a space for the grains to expand without deforming the mold. Olivine, Chromite, etc. are used because they do not have a phase conversion that causes rapid expansion of the grains, as well as offering greater density, which cools the metal faster and produces finer grain structures in the

metal. Since they are not metamorphic minerals, they do not have the polycrystals found in silica, and subsequently do not form hazardous sub-micron sized particles.

## **The "air set" method**

The air set method uses dry sand bonded with materials other than clay, using a fast curing adhesive. The latter may also be referred to as no bake mold casting. When these are used, they are collectively called "air set" sand castings to distinguish them from "green sand" castings. Two types of molding sand are natural bonded (bank sand) and synthetic (lake sand); the latter is generally preferred due to its more consistent composition.

With both methods, the sand mixture is packed around a pattern, forming a mold cavity. If necessary, a temporary plug is placed in the sand and touching the pattern in order to later form a channel into which the casting fluid can be poured. Air-set molds are often formed with the help of a casting flask having a top and bottom part, termed the cope and drag. The sand mixture is tamped down as it is added around the pattern, and the final mold assembly is sometimes vibrated to compact the sand and fill any unwanted voids in the mold. Then the pattern is removed along with the channel plug, leaving the mold cavity. The casting liquid (typically molten metal) is then poured into the mold cavity. After the metal has solidified and cooled, the casting is separated from the sand mold. There is typically no mold release agent, and the mold is generally destroyed in the removal process.

The accuracy of the casting is limited by the type of sand and the molding process. Sand castings made from coarse green sand impart a rough texture to the surface, and this makes them easy to identify. Castings made from fine green sand can shine as cast but are limited by the depth to width ratio of pockets in the pattern. Air-set molds can produce castings with smoother surfaces than coarse green sand but this method is primarily chosen when deep narrow pockets in the pattern are necessary, due to the expense of the plastic used in the process. Air-set castings can typically be easily identified by the burnt color on the surface. The castings are typically shot blasted to remove that burnt color. Surfaces can also be later ground and polished, for example when making a large bell. After molding, the casting is covered with a residue of oxides, silicates and other compounds. This residue can be removed by various means, such as grinding, or shot blasting.

During casting, some of the components of the sand mixture are lost in the thermal casting process. Green sand can be reused after adjusting its composition to replenish the lost moisture and additives. The pattern itself can be reused indefinitely to produce new sand molds. The sand molding process has been used for many centuries to produce castings manually. Since 1950, partially automated casting processes have been developed for production lines.

## **Mold Materials**

There are four main components for making a sand casting mold: base sand, a binder, additives, and a parting compound.

## **Molding Sands**

Molding sands, also known as foundry sands, are defined by eight characteristics: refractoriness, chemical inertness, permeability, surface finish, cohesiveness, flowability, collapsibility, and availability/cost.

**Refractoriness** — This refers to the sand's ability to withstand the temperature of the liquid metal being cast without breaking down. For example some sands only need to withstand 650 °C (1,202 °F) if casting aluminum alloys, whereas steel needs a sand that will withstand 1,500 °C (2,730 °F). Sand with too low a refractoriness will melt and fuse to the casting.

**Chemical inertness** — The sand must not react with the metal being cast. This is especially important with highly reactive metals, such as magnesium and titanium.

**Permeability** — This refers to the sand's ability to exhaust gases. This is important because during the pouring process many gases are produced, such as hydrogen, nitrogen, carbon dioxide, and steam, which must leave the mold otherwise casting defects, such as blow holes and gas holes, occur in the casting. Note that for each cubic centimeter (cc) of water added to the mold 16,000 cc of steam is produced.

**Surface finish** — The size and shape of the sand particles defines the best surface finish achievable, with finer particles producing a better finish. However, as the particles become finer (and surface finish improves) the permeability becomes worse.

Cohesiveness (or bond) — This is the ability of the sand to retain a given shape after the pattern is removed.

Flowability – The ability for the sand to flow into intricate details and tight corners without special processes or equipment.

Collapsibility — This is the ability of the sand to be easily stripped off the casting after it has solidified. Sands with poor collapsibility will adhere strongly to the casting. When casting metals that contract a lot during cooling or with long freezing temperature ranges a sand with poor collapsibility will cause cracking and hot tears in the casting. Special additives can be used to improve collapsibility.

Availability/cost — The availability and cost of the sand is very important because for every ton of metal poured, three to six tons of sand is required. Although sand can be screened and reused, the particles eventually become too fine and require periodic replacement with fresh sand.

In large castings it is economical to use two different sands, because the majority of the sand will not be in contact with the casting, so it does not need any special properties. The sand that is in contact with the casting is called facing sand, and is designed for the casting on hand. This sand will be built up around the pattern to a thickness of 30 to 100 mm (1.2 to 3.9 in). The sand that fills in around the facing sand is called backing sand. This sand is simply silica sand with only a small amount of binder and no special additives.

## **Types of base sands**

Base sand is the type used to make the mold or core without any binder. Because it does not have a binder it will not bond together and is not usable in this state.

### **Silica sand**

Silica ( $\text{SiO}_2$ ) sand is the sand found on a beach and is also the most commonly used sand. It is made by either crushing sandstone or taken from natural occurring locations, such as beaches and river beds. The fusion point of pure silica is  $1,760\text{ }^\circ\text{C}$  ( $3,200\text{ }^\circ\text{F}$ ), however the sands used have a lower melting point due to impurities. For high melting point casting, such as steels, a

minimum of 98% pure silica sand must be used; however for lower melting point metals, such as cast iron and non-ferrous metals, a lower purity sand can be used (between 94 and 98% pure).

Silica sand is the most commonly used sand because of its great abundance, and, thus, low cost (therein being its greatest advantage). Its disadvantages are high thermal expansion, which can cause casting defects with high melting point metals, and low thermal conductivity, which can lead to unsound casting. It also cannot be used with certain basic metal because it will chemically interact with the metal forming surface defect. Finally, it causes silicosis in foundry workers.

### **Olivine sand**

Olivine is a mixture of orthosilicates of iron and magnesium from the mineral dunite. Its main advantage is that it is free from silica, therefore it can be used with basic metals, such as manganese steels. Other advantages include a low thermal expansion, high thermal conductivity, and high fusion point. Finally, it is safer to use than silica, therefore it is popular in Europe.

### **Binders**

Binders are added to a base sand to bond the sand particles together (i.e. it is the glue that holds the mold together).

#### Clay and water

A mixture of clay and water is the most commonly used binder. There are two types of clay commonly used: bentonite and kaolinite, with the former being the most common.

### **Oil**

Oils, such as linseed oil, other vegetable oils and marine oils, used to be used as a binder, however due to their increasing cost, they have been mostly phased out. The oil also required careful baking at 100 to 200 °C (212 to 392 °F) to cure (if overheated the oil becomes brittle, wasting the mold).



## Resin

Resin binders are natural or synthetic high melting point gums. The two common types used are urea formaldehyde (UF) and phenol formaldehyde (PF) resins. PF resins have a higher heat resistance than UF resins and cost less. There are also cold-set resins, which use a catalyst instead of a heat to cure the binder. Resin binders are quite popular because different properties can be achieved by mixing with various additives. Other advantages include good collapsibility, low gassing, and they leave a good surface finish on the casting.

MDI (methylene diphenyl diisocyanate) is also a commonly used binder resin in the foundry core process.

## Sodium Silicate

Sodium silicate [ $\text{Na}_2\text{SiO}_3$  or  $(\text{Na}_2\text{O})(\text{SiO}_2)$ ] is a high strength binder used with silica molding sand. To cure the binder carbon dioxide gas is used, which creates the following reaction:

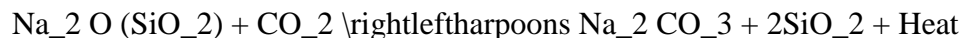

The advantage to this binder is that it can be used at room temperature and it's fast. The disadvantage is that its high strength leads to shakeout difficulties and possibly hot tears in the casting.

## Additives

Additives are added to the molding components to improve: surface finish, dry strength, refractoriness, and "cushioning properties".

Up to 5% of reducing agents, such as coal powder, pitch, creosote, and fuel oil, may be added to the molding material to prevent wetting (prevention of liquid metal sticking to sand particles, thus leaving them on the casting surface), improve surface finish, decrease metal penetration, and burn-on defects. These additives achieve this by creating gases at the surface of the mold cavity, which prevent the liquid metal from adhering to the sand. Reducing agents are not used with steel casting, because they can carburize the metal during casting.

Up to 3% of "cushioning material", such as wood flour, saw dust, powdered husks, peat, and straw, can be added to reduce scabbing, hot tear, and hot crack casting defects when casting high temperature metals. These materials are beneficial because burn-off when the metal is poured creating voids in the mold, which allow it to expand. They also increase collapsibility and reduce shakeout time.

## **Parting Compounds**

To get the pattern out of the mold, prior to casting, a parting compound is applied to the pattern to ease removal. They can be a liquid or a fine powder (particle diameters between 75 and 150 micrometres (0.0030 and 0.0059 in)). Common powders include talc, graphite, and dry silica; common liquids include mineral oil and water-based silicon solutions. The latter are more commonly used with metal and large wooden patterns.

## **CHAPTER - 4**

### **Plaster Mold Casting**

Plaster mold casting is a metalworking casting process similar to sand casting except the molding material is plaster of paris instead of sand. Like sand casting, plaster mold casting is an expendable mold process, however it can only be used with non-ferrous materials. It is used for castings as small as 30 g (1 oz) to as large as 45 kg (99 lb). Generally, the form takes less than a week to prepare. Production rates of 1–10 units/hr can be achieved with plaster molds.

Parts that are typically made by plaster casting are lock components, gears, valves, fittings, tooling, and ornaments.

The plaster is not pure plaster of paris, but rather has additives to improve green strength, dry strength, permeability, and castability. For instance, talc or magnesium oxide are added to prevent cracking and reduce setting time; lime and cement limit expansion during baking; glass fibers increase strength; sand can be used as a filler. The ratio of ingredients is 70–80% gypsum and 20–30% additives.

The pattern is usually made from metal, however rubber molds may be used for complex geometry; these molds are called Rubber plaster molds. For example, if the casting includes reentrant angles or complex angular surfaces then the rubber is flexible enough to be removed, unlike metal. These molds are also inexpensive, reusable, more accurate than steel molds, fast to produce, and easy to change.

Typical tolerances are 0.1 mm (0.0039 in) for the first 50 mm (2.0 in) and 0.02 mm per additional centimeter (0.002 in per additional inch). A draft of 0.5 to 1 degree is required. Standard surface finishes that are attainable are 1.3 to 4 micrometres (50–125  $\mu\text{in}$ ).

## **Process**

First, the plaster is mixed and the pattern is sprayed with a thin film of parting compound to prevent the plaster from sticking to the pattern. The plaster is then poured over the pattern and the unit shaken so that the plaster fills any small features. The plaster sets, usually in about 15 minutes, and the pattern is removed. The mold is then baked, between 120 °C (248 °F) and 260 °C (500 °F), to remove any excess water. The dried mold is then assembled, preheated, and the metal poured. Finally, after the metal has solidified, the plaster is broken from the cast part. The used plaster cannot be reused.

## **Advantages and Disadvantages**

Plaster mold casting is used when an excellent surface finish and good dimensional accuracy is required. Because the plaster has a low thermal conductivity and heat capacity the metal cools more slowly than in a sand mold, which allows the metal to fill thin cross-sections; the minimum possible cross-section is 0.6 mm (0.024 in). This results in a near net shape casting, which can be a cost advantage on complex parts. It also produces minimal scrap material.

The major disadvantage of the process is that it can only be used with lower melting temperature non-ferrous materials, such as aluminium, copper, magnesium, and zinc. The most commonly used materials are aluminium and copper. The maximum working temperature of plaster is 1,200 °C (2,200 °F), so higher melting temperature materials would melt the plaster mold. Also, the sulfur in the gypsum reacts with iron, making it unsuitable for casting ferrous materials.

Another disadvantage is that its long cooling times restrict production volume.

Plaster is not as stable as sand, so it is dependent on several factors, including the consistency of the plaster composition, pouring procedures, and curing techniques. If these factors are not closely monitored the mold can be distorted, shrink upon drying, have a poor surface finish, or fail completely.

Metalworking is the process of working with metals to create individual parts, assemblies, or large-scale structures. The term covers a wide range of work from large ships and bridges to precise engine parts and delicate jewelry. It therefore includes a correspondingly wide range of skills, processes, and tools.

Metalworking is a science, art, hobby, industry and trade. Its historical roots span cultures, civilizations, and millennia. Metalworking has evolved from the discovery of smelting various ores, producing malleable and ductile metal useful for tools and adornments. Modern metalworking processes, though diverse and specialized, can be categorized as forming, cutting, or joining processes. Today's machine shop includes a number of machine tools capable of creating a precise, useful work piece

Plaster is a building material used for coating walls and ceilings. Plaster starts as a dry powder similar to mortar or cement and like those materials it is mixed with water to form a paste which liberates heat and then hardens. Unlike mortar and cement, plaster remains quite soft after setting, and can be easily manipulated with metal tools or even sandpaper. These characteristics make plaster suitable for a finishing, rather than a load-bearing material.

The term plaster can refer to gypsum plaster (also known as plaster of Paris), lime plaster, or cement plaster.

## **Types:**

### **Gypsum plaster (plaster of Paris)**

Gypsum plaster, or plaster of Paris, is produced by heating gypsum to about 300 °F (150 °C)

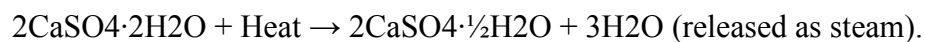

When the dry plaster powder is mixed with water, it re-forms into gypsum. The setting of unmodified plaster starts about 10 minutes after mixing and is complete in about 45 minutes; but not fully set for 72 hours. If plaster or gypsum is heated above 392°F (200°C), anhydrite is formed, which will also re-form as gypsum if mixed with water.

A large gypsum deposit at Montmartre in Paris led "calcined gypsum" (roasted gypsum or gypsum plaster) to be commonly known as "plaster of Paris".

Plasterers often use gypsum to simulate the appearance of surfaces of wood, stone, or metal, on movie and theatrical sets for example. Nowadays, theatrical plasterers often use expanded polystyrene, although the job title remains unchanged.

Plaster of Paris can be used to impregnate gauze bandages to make a sculpting material called modroc. It is used similarly to clay, as it is easily shaped when wet, yet sets into a resilient and lightweight structure. This is the material that was (and sometimes still is) used to make classic plaster orthopedic casts to protect limbs with broken bones, the medical use having been partly inspired by the artistic use. Set modroc is an early example of a composite material.

#### Technical details

Depending on the temperature and duration of the heating process, gypsum converts to the hemihydrate or an anhydrous form. Two polymorphs are known of the hemihydrate. The anhydrous calcium sulfate occurs in three forms, called anhydrite I, II, and III. Each form hydrates differently. The hemihydrate converts to the dihydrate. The anhydrite III converted via the hemihydrate, whereas anhydrite II is converted directly into dihydrate without forming intermediates.

## **Lime Plaster**

Lime plaster is a mixture of calcium hydroxide and sand (or other inert fillers). Carbon dioxide in the atmosphere causes the plaster to set by transforming the calcium hydroxide into calcium carbonate (limestone). Whitewash is based on the same chemistry.

To make lime plaster, limestone (calcium carbonate) is heated to produce quicklime (calcium oxide). Water is then added to produce slaked lime (calcium hydroxide), which is sold as a wet

putty or a white powder. Additional water is added to form a paste prior to use. The paste may be stored in air-tight containers. Once exposed to the atmosphere, the calcium hydroxide turns back into calcium carbonate, causing the plaster to set.

Lime plaster was a common building material for wall surfaces in a process known as lath and plaster, whereby a series of wooden strips on a studwork frame was covered with a semi-dry plaster that hardened into a surface. The plaster used in most lath and plaster construction was mainly lime plaster, with a cure time of about a month. To stabilize the lime plaster during curing, small amounts of plaster of Paris were incorporated into the mix. Because plaster of Paris sets quickly, "retardants" were used to slow setting time enough to allow workers to mix large working quantities of lime putty plaster. A modern form of this method uses expanded metal mesh over wood or metal structures, which allows a great freedom of design as it is adaptable to both simple and compound curves. Today this building method has been partly replaced with drywall, also composed mostly of gypsum plaster. In both these methods a primary advantage of the material is that it is resistant to a fire within a room and so can assist in reducing or eliminating structural damage or destruction provided the fire is promptly extinguished.

Lime plaster is used for frescoes, where pigments, diluted in water, are applied to the still wet plaster. USA and Iran are the main plaster producers in the world.

## **Cement Plaster**

Cement plaster is a mixture of suitable plaster, sand, portland cement and water which is normally applied to masonry interiors and exteriors to achieve a smooth surface. Interior surfaces sometimes receive a final layer of gypsum plaster. Walls constructed with stock bricks are normally plastered while face brick walls are not plastered. Various cement-based plasters are also used as proprietary spray fireproofing products. These usually use vermiculite as lightweight aggregate. Heavy versions of such plasters are also in use for exterior fireproofing, to protect LPG vessels, pipe bridges and vessel skirts.

Cement plaster was first introduced in America around 1909 and was often called by the generic name adamant plaster after a prominent manufacturer of the time. The advantages of cement plaster noted at that time were its strength, hardness, quick setting time and durability.

## **Plasterwork**

Plaster may also be used to create complex detailing for use in room interiors. These may be geometric (simulating wood or stone) or naturalistic (simulating leaves, vines, and flowers) These are also often used to simulate wood or stone detailing found in more substantial buildings.

## **In Art**

Many of the greatest mural paintings in Europe, like Michelangelo's Sistine Chapel ceiling are executed in fresco, meaning they are painted on a thin layer of wet plaster, called intonaco; the pigments sink into this layer so that the plaster itself becomes the medium holding them, which accounts for the excellent durability of fresco. Additional work may be added a secco on top of the dry plaster, though this is generally less durable.

Plaster may be cast directly into a damp clay mold. In creating this piece molds (molds designed for making multiple copies) or waste molds (for single use) would be made of plaster. This "negative" image, if properly designed, may be used to produce clay productions, which when fired in a kiln become terra cotta building decorations, or these may be used to create cast concrete sculptures. If a plaster positive was desired this would be constructed or cast to form a durable image artwork. As a model for stonecutters this would be sufficient. If intended for producing a bronze casting the plaster positive could be further worked to produce smooth surfaces. An advantage of this plaster image is that it is relatively cheap; should a patron approve of the durable image and be willing to bear further expense, subsequent molds could be made for the creation of a wax image to be used in lost wax casting, a far more expensive process. In lieu of producing a bronze image suitable for outdoor use the plaster image may be painted to resemble a metal image; such sculptures are suitable only for presentation in a weather-protected environment.

Plaster expands while hardening, then contracts slightly just before hardening completely. This makes plaster excellent for use in molds, and it is often used as an artistic material for casting. Plaster is also commonly spread over an armature (form), usually made of wire, mesh or other materials, a process raised details. For these processes, limestone or acrylic based plaster may be employed.

## **In Medicine**

Plaster is widely used as a support for broken bones; a bandage impregnated with plaster is moistened and then wrapped around the damaged limb, setting into a close-fitting yet easily removed tube, known as an orthopedic cast.

Plaster is also used within radiotherapy when making immobilization casts for patients. Plaster bandages are used when constructing an impression of the patients head and neck, and liquid plaster is used to fill the impression and produce a plaster bust. Perspex is then vacuum formed over this bust creating an immobilization shell.

In dentistry, plaster is used for mounting casts or models of oral tissues. These diagnostic and working models are usually made from dental stone, a stronger, harder and denser derivative of plaster which is manufactured from gypsum under pressure. Plaster is also used to invest or flask wax dentures, the wax being subsequently removed and replaced with the final denture base material which is cured in the plaster mold.

In orthotics and prosthetics, plaster bandages traditionally where used to create impressions of the patients limb (or residuum). This negative impression was then, itself, filled with plaster of paris, to create a positive model of the limb and used in fabricating the final medial device.

In addition, dentures (false teeth) are made by first taking a dental impression using a soft, pliable material that can be removed from around the teeth and gums without loss of fidelity and using the impression to creating a wax model of the teeth and gums. The model is used to create a plaster mold (which is heated so the wax melts and flows out) and the denture materials are injected into the mold. After a curing period, the mold is opened and the dentures are cleaned up and polished.



## **In Fire Protection**

Plasters have been in use in passive fire protection, as fireproofing products, for many decades.

The finished plaster releases water vapor when exposed to flame, acting to slow the spread of the fire, for as much as an hour or two depending on thickness. It also provides some insulation to retard heat flow into structural steel elements, that would otherwise lose their strength and collapse in a fire. Early versions of these plasters have used asbestos fibres, which have by now been outlawed in industrialized nations and have caused significant removal and re-coating work. More modern plasters fall into the following categories.

Fibrous (including mineral wool and glass fiber)

Cement mixtures either with mineral wool or with vermiculite

Gypsum plasters, leavened with polystyrene beads, as well as chemical expansion agents to decrease the density of the finished product

One differentiates between interior and exterior fireproofing. Interior products are typically less substantial, with lower densities and lower cost. Exterior products have to withstand more extreme fire and other environmental conditions. Exterior products are also more likely to be attractively tooled, whereas their interior cousins are usually merely sprayed in place. A rough surface is typically forgiven inside of buildings as dropped ceilings often hide them. Exterior fireproofing plasters are losing ground to more costly intumescent and endothermic products, simply on technical merit. Trade jurisdiction on unionized construction sites in North America remains with the plasterers, regardless of whether the plaster is decorative in nature or is used in passive fire protection. Cementitious and gypsum based plasters tend to be endothermic. Fireproofing plasters are closely related to firestop mortars. Most firestop mortars can be sprayed and tooled very well, due to the fine detail work that is required of firestopping, which leads their mix designers to utilise concrete admixtures, that enable easier tooling than common mortars.

## **In Industry**

It is used in glass making, tanning, bleaching powder making and purification of sugar.

## CHAPTER - 5

### Shell Molding

Shell molding, also known as shell-mold casting, is an expendable mold casting process that uses a resin covered sand to form the mold. As compared to sand casting, this process has better dimensional accuracy, a higher productivity rate, and lower labor requirements. It is used for small to medium parts that require high precision. Shell mold casting is a metal casting process similar to sand casting, in that molten metal is poured into an expendable mold. However, in shell mold casting, the mold is a thin-walled shell created from applying a sand-resin mixture around a pattern. The pattern, a metal piece in the shape of the desired part, is reused to form multiple shell molds. A reusable pattern allows for higher production rates, while the disposable molds enable complex geometries to be cast. Shell mold casting requires the use of a metal pattern, oven, sand-resin mixture, dump box, and molten metal.

Shell mold casting allows the use of both ferrous and non-ferrous metals, most commonly using cast iron, carbon steel, alloy steel, stainless steel, aluminum alloys, and copper alloys. Typical parts are small-to-medium in size and require high accuracy, such as gear housings, cylinder heads, connecting rods, and lever arms.

The shell mold casting process consists of the following steps:

**Pattern creation** - A two-piece metal pattern is created in the shape of the desired part, typically from iron or steel. Other materials are sometimes used, such as aluminum for low volume production or graphite for casting reactive materials.

**Mold creation** - First, each pattern half is heated to 175-370°C (350-700°F) and coated with a lubricant to facilitate removal. Next, the heated pattern is clamped to a dump box, which contains a mixture of sand and a resin binder. The dump box is inverted, allowing this sand-resin mixture to coat the pattern. The heated pattern partially cures the mixture, which now forms a shell around the pattern. Each pattern half and surrounding shell is cured to completion in an oven and then the shell is ejected from the pattern.

**Mold assembly** - The two shell halves are joined together and securely clamped to form the complete shell mold. If any cores are required, they are inserted prior to closing the mold. The shell mold is then placed into a flask and supported by a backing material.

**Pouring** - The mold is securely clamped together while the molten metal is poured from a ladle into the gating system and fills the mold cavity.

**Cooling** - After the mold has been filled, the molten metal is allowed to cool and solidify into the shape of the final casting.

**Casting removal** - After the molten metal has cooled, the mold can be broken and the casting removed. Trimming and cleaning processes are required to remove any excess metal from the feed system and any sand from the mold.

Examples of shell molded items include gear housings, cylinder heads and connecting rods. It is also used to make high-precision molding cores.

## **Process**

The process of creating a shell mold consists of six steps:

Fine silica sand that is covered in a thin (3–6%) thermosetting phenolic resin and liquid catalyst is dumped, blown, or shot onto a hot pattern. The pattern is usually made from cast iron and is heated to 230 to 315 °C (450 to 600 °F). The sand is allowed to sit on the pattern for a few minutes to allow the sand to partially cure.

The pattern and sand are then inverted so the excess sand drops free of the pattern, leaving just the "shell". Depending on the time and temperature of the pattern the thickness of the shell is 10 to 20 mm (0.4 to 0.8 in).

The pattern and shell together are placed in an oven to finish curing the sand. The shell now has a tensile strength of 350 to 450 psi (2.4 to 3.1 MPa).

The hardened shell is then stripped from the pattern.

Two or more shells are then combined, via clamping or gluing using a thermoset adhesive, to form a mold. This finished mold can then be used immediately or stored almost indefinitely.

For casting the shell mold is placed inside a flask and surrounded with shot, sand, or gravel to reinforce the shell.

The machine that is used for this process is called a shell molding machine. It heats the pattern, applies the sand mixture, and bakes the shell.

Setup and production of shell mold patterns takes weeks, after which an output of 5–50 pieces/hr-mold is attainable. Common materials include cast iron, aluminum and copper alloys. Aluminum and magnesium products average about 13.5 kg (30 lb) as a normal limit, but it is possible to cast items in the 45–90 kg (100–200 lb) range. The small end of the limit is 30 g (1 oz). Depending on the material, the thinnest cross-section castable is 1.5 to 6 mm (0.06 to 0.24 in). The minimum draft is 0.25 to 0.5 degrees.

Typical tolerances are 0.005 mm/mm or in/in because the sand compound is designed to barely shrink and a metal pattern is used. The cast surface finish is 0.3–4.0 micrometers (50–150  $\mu\text{in}$ ) because finer sand is used. The resin also assists in forming a very smooth surface. The process, in general, produces very consistent castings from one casting to the next.

The sand-resin mix can be recycled by burning off the resin at high temperatures.

## **Advantages And Disadvantages**

One of the greatest advantages of this process is that it can be completely automated for mass production. The high productivity, low labor costs, good surface finishes, and precision of the process can more than pay for itself if it reduces machining costs. There are also few problems due to gases, because of the absence of moisture in the shell, and the little gas that is still present easily escapes through the thin shell. When the metal is poured some of the resin binder burns out on the surface of the shell, which makes shaking out easy.

One disadvantage is that the gating system must be part of the pattern because the entire mold is formed from the pattern, which can be expensive. Another is the resin for the sand is expensive, however not much is required because only a shell is being formed.

Property Name Shell Mold Casting Sand Casting Shapes Thin-walled: Complex, Solid: Cylindrical, Solid: Cubic, Solid: Complex (Flat, Thin-walled: Cylindrical, Thin-walled: Cubic)

Thin-walled: Complex, Solid: Cylindrical, Solid: Cubic, Solid: Complex (Flat, Thin-walled: Cylindrical, Thin-walled: Cubic) Part size Weight: 0.5 oz - 220 lb Weight: 1 oz - 450 ton Materials Metals, Alloy Steel, Carbon Steel, Cast Iron, Stainless Steel, Aluminum, Copper, Nickel Metals, Alloy Steel, Carbon Steel, Cast Iron, Stainless Steel, Aluminum, Copper, Magnesium, Nickel (Lead, Tin, Titanium, Zinc) Surface finish - Ra ( $\mu\text{in}$ ) 50 - 300 (32 - 500) 300 - 600 (125 - 2000) Tolerance (in.)  $\pm 0.015$  ( $\pm 0.006$ )  $\pm 0.03$  ( $\pm 0.015$ ) Max wall thickness 0.06 - 2.0 0.125 - 5 (0.09 - 40) Quantity 1000 - 1000000 (100 - 1000000) 1 - 1000 (1 - 1000000) Lead time Weeks (Days) Days (Hours)

**Advantages:** Can form complex shapes and fine details, Very good surface finish, High production rate, Low labor cost, Low tooling cost, Little scrap generated. Can produce very large parts, Can form complex shapes, Many material options, Low tooling and equipment cost, Scrap can be recycled, Short lead time possible.

**Disadvantages:** High equipment cost, Poor material strength, High porosity possible, Poor surface finish and tolerance, Secondary machining often required, Low production rate, High labor cost.

**Applications:** Cylinder heads, connecting rods Engine blocks and manifolds, machine bases, gears, pulleys.

Resin in the most specific use of the term is a hydrocarbon secretion of many plants, particularly coniferous trees. Resins are valued for their chemical properties and associated uses, such as the production of varnishes, adhesives and food glazing agents. They are also prized as an important source of raw materials for organic synthesis, and as constituents of incense and perfume. Plant resins have a very long history that was documented in ancient Greece by Theophrastus, in ancient Rome by Pliny the Elder, and especially in the resins known as frankincense and myrrh, prized in ancient Egypt. These were highly prized substances, and required as incense in some religious rites. Amber is a hard fossilized resin from ancient trees.

More broadly, the term "resin" also encompasses a great many synthetic substances of similar mechanical properties (thick liquids that harden into transparent solids), as well as shellacs of insects of the superfamily Coccoidea.

Other liquid compounds found inside plants or exuded by plants, such as sap, latex, or mucilage, are sometimes confused with resin, but are not chemically the same. Saps, in particular, serve a nutritive function that resins do not. There is no consensus on why plants secrete resins. However, resins consist primarily of secondary metabolites or compounds that apparently play no role in the primary physiology of a plant. While some scientists view resins only as waste products, their protective benefits to the plant are widely documented. The toxic resinous compounds may confound a wide range of herbivores, insects, and pathogens; while the volatile phenolic compounds may attract benefactors such as parasitoids or predators of the herbivores that attack the plant.

The word "resin" has been applied in the modern world to nearly any component of a liquid that will set into a hard lacquer or enamel-like finish. An example is nail polish, a modern product which contains "resins" that are organic compounds, but not classical plant resins. Certain "casting resins" and synthetic resins (such as epoxy resin) have also been given the name "resin" because they solidify in the same way as some plant resins, but synthetic resins are liquid monomers of thermosetting plastics, and do not derive from plants.

#### Resin of a pine

The resin produced by most plants is a viscous liquid, composed mainly of volatile fluid terpenes, with lesser components of dissolved non-volatile solids which make resin thick and sticky. The most common terpenes in resin are the bicyclic terpenes alpha-pinene, beta-pinene, delta-3 carene and sabinene, the monocyclic terpenes limonene and terpinolene, and smaller amounts of the tricyclic sesquiterpenes, longifolene, caryophyllene and delta-cadinene. Some resins also contain a high proportion of resin acids. The individual components of resin can be separated by fractional distillation.

A few plants produce resins with different compositions, most notably Jeffrey Pine and Gray Pine, the volatile components of which are largely pure n-heptane with little or no terpenes. The exceptional purity of the n-heptane distilled from Jeffrey Pine resin, unmixed with other isomers of heptane, led to its being used as the defining zero point on the octane rating scale of petrol quality. Because heptane is highly flammable, distillation of resins containing it is very dangerous. Some resin distilleries in California exploded because they mistook Jeffrey Pine for

the similar but terpene-producing Ponderosa Pine. At the time the two pines were considered to be the same species of pine; they were only classified as separate species in 1853.

Some resins when soft are known as 'oleoresins', and when containing benzoic acid or cinnamic acid they are called balsams. Oleoresins are naturally occurring mixtures of an oil and a resin; they can be extracted from various plants. Other resinous products in their natural condition are a mix with gum or mucilaginous substances and known as gum resins. Many compound resins have distinct and characteristic odors, from their admixture with essential oils.

Certain resins are obtained in a fossilized condition, amber being the most notable instance of this class; African copal and the kauri gum of New Zealand are also procured in a semi-fossil condition.

Solidified resin from which the volatile terpene components have been removed by distillation is known as rosin. Typical rosin is a transparent or translucent mass, with a vitreous fracture and a faintly yellow or brown colour, non-odorous or having only a slight turpentine odour and taste.

It is insoluble in water, mostly soluble in alcohol, essential oils, ether and hot fatty oils, and softens and melts under the influence of heat, is not capable of sublimation, and burns with a bright but smoky flame.

This comprises a complex mixture of different substances including organic acids named the resin acids. These are closely related to the terpenes, and derive from them through partial oxidation. Resin acids can be dissolved in alkalis to form resin soaps, from which the purified resin acids are regenerated by treatment with acids. Examples of resin acids are abietic acid (sylvic acid),  $C_{20}H_{30}O_2$ , plicatic acid contained in cedar, and pimaric acid,  $C_{20}H_{30}O_2$ , a constituent of galipot resin. Abietic acid can also be extracted from rosin by means of hot alcohol; it crystallizes in leaflets, and on oxidation yields trimellitic acid, isophthalic acid and terebic acid. Pimaric acid closely resembles abietic acid into which it passes when distilled in a vacuum; it has been supposed to consist of three isomers.

## **Uses**

The hard transparent resins, such as the copals, dammars, mastic and sandarac, are principally used for varnishes and adhesives, while the softer odoriferous oleo-resins (frankincense, elemi,

turpentine, copaiba) and gum resins containing essential oils (ammoniacum, asafoetida, gamboge, myrrh, and scammony) are more largely used for therapeutic purposes and incense.

Resin in the form of rosin is applied to the bows of musical string instruments because of its ability to add friction to the hair to increase sound quality.

Ballet dancers, as well as boxers in the old days, may apply crushed resin to their shoes to increase grip on a slippery floor.

Resin has also been used as a medium for sculpture by artists such as Eva Hesse, and in other types of artwork.

In the early 1990s, most ten-pin bowling ball manufacturers started adding resin particles to the covers of bowling balls. Resin makes a bowling ball tackier than it would otherwise be, increasing its ability to hook into the pins at an angle and (with correct technique) making strikes easier to achieve.

Resin is also used in stereolithography.

## **CHAPTER - 6**

### **Investment Casting**

Investment casting is an industrial process based on and also called lost-wax casting, one of the oldest known metal-forming techniques. From 5,000 years ago, when beeswax formed the pattern, to today's high-technology waxes, refractory materials and specialist alloys, the castings allow the production of components with accuracy, repeatability, versatility and integrity in a variety of metals and high-performance alloys. Lost-foam casting is a modern form of investment casting that eliminates certain steps in the process.

The process is generally used for small castings, but has been used to produce complete aircraft door frames, steel castings of up to 300 kg (660 lbs) and aluminium castings of up to 30 kg (66 lbs). It is generally more expensive per unit than die casting or sand casting, but has lower



equipment costs. It can produce complicated shapes that would be difficult or impossible with die casting, yet like that process, it requires little surface finishing and only minor machining.

A wax pattern used to create a jet engine turbine blade

Casts can be made of the wax model itself, the direct method; or of a wax copy of a model that need not be of wax, the indirect method. The following steps are for the indirect process which can take two days to one week to complete.

Produce a master pattern: An artist or mould-maker creates an original pattern from wax, clay, wood, plastic, steel, or another material.

**Mouldmaking:** A mould, known as the master die, is made of the master pattern. The master pattern may be made from a low-melting-point metal, steel, or wood. If a steel pattern was created then a low-melting-point metal may be cast directly from the master pattern. Rubber moulds can also be cast directly from the master pattern. The first step may also be skipped if the master die is machined directly into steel.

**Produce the wax patterns:** Although called a wax pattern, pattern materials also include plastic and frozen mercury. Wax patterns may be produced in one of two ways. In one process the wax is poured into the mold and swished around until an even coating, usually about 3 mm (0.12 in) thick, covers the inner surface of the mould. This is repeated until the desired thickness is reached. Another method is filling the entire mould with molten wax, and let it cool, until a desired thickness has set on the surface of the mould. After this the rest of the wax is poured out again, the mould is turned upside down and the wax layer is left to cool and harden. With this method it is more difficult to control the overall thickness of the wax layer.

If a core is required, there are two options: soluble wax or ceramic. Soluble wax cores are designed to melt out of the investment coating with the rest of the wax pattern, whereas ceramic cores remain part of the wax pattern and are removed after the workpiece is cast.

**Assemble the wax patterns:** The wax pattern is then removed from the mould. Depending on the application multiple wax patterns may be created so that they can all be cast at once. In other applications, multiple different wax patterns may be created and then assembled into one complex pattern. In the first case the multiple patterns are attached to a wax sprue, with the result

known as a pattern cluster, or tree; as many as several hundred patterns may be assembled into a tree. Foundries often use registration marks to indicate exactly where they go. The wax patterns are attached to the sprue or each other by means of a heated metal tool. The wax pattern may also be chased, which means the parting line or flashing are rubbed out using the heated metal tool. Finally it is dressed, which means any other imperfections are addressed so that the wax now looks like the finished piece.

**Investment:** The ceramic mould, known as the investment, is produced by three repeating steps: coating, stuccoing, and hardening. The first step involves dipping the cluster into a slurry of fine refractory material and then letting any excess drain off, so a uniform surface is produced. This fine material is used first to give a smooth surface finish and reproduce fine details. In the second step, the cluster is stuccoed with a coarse ceramic particle, by dipping it into a fluidised bed, placing it in a rainfall-sander, or by applying by hand. Finally, the coating is allowed to harden. These steps are repeated until the investment is the required thickness, which is usually 5 to 15 mm (0.2 to 0.6 in). Note that the first coatings are known as prime coats. An alternative to multiple dips is to place the cluster upside-down in a flask and then liquid investment material is poured into the flask. The flask is then vibrated to allow entrapped air to escape and help the investment material fill in all of the details.

Common refractory materials used to create the investments are: silica, zircon, various aluminium silicates, and alumina. Silica is usually used in the fused silica form, but sometimes quartz is used because it is less expensive. Aluminium silicates are a mixture of alumina and silica, where commonly used mixtures have an alumina content from 42 to 72%; at 72% alumina the compound is known as mullite. During the primary coat(s), zircon-based refractories are commonly used, because zirconium is less likely to react with the molten metal. Chamotte is another refractory material that has been used. Prior to silica, a mixture of plaster and ground up old molds (chamotte) was used.

The binders used to hold the refractory material in place include: ethyl silicate (alcohol-based and chemically set), colloidal silica (water-based, also known as silica sol, set by drying), sodium silicate, and a hybrid of these controlled for pH and viscosity.

**Dewax:** The investment is then allowed to completely dry, which can take 16 to 48 hours. Drying can be enhanced by applying a vacuum or minimizing the environmental humidity. It is then turned upside-down and placed in a furnace or autoclave to melt out and/or vaporize the wax. Most shell failures occur at this point because the waxes used have a thermal expansion coefficient that is much greater than the investment material surrounding it, so as the wax is heated it expands and induces great stresses. In order to minimize these stresses the wax is heated as rapidly as possible so that the surface of the wax can melt into the surface of the investment or run out of the mold, which makes room for the rest of the wax to expand. In certain situations holes may be drilled into the mold beforehand to help reduce these stresses. Any wax that runs out of the mold is usually recovered and reused.

**Burnout & preheating:** The mold is then subjected to a burnout, which heats the mold between 870 °C and 1095 °C to remove any moisture and residual wax, and to sinter the mold. Sometimes this heating is also used as the preheat, but other times the mold is allowed to cool so that it can be tested. If any cracks are found they can be repaired with ceramic slurry or special cements. The mold is preheated to allow the metal to stay liquid longer to fill any details and to increase dimensional accuracy, because the mold and casting cool together.

**Pouring:** The investment mold is then placed cup-upwards into a tub filled with sand. The metal may be gravity poured, but if there are thin sections in the mold it may be filled by applying positive air pressure, vacuum cast, tilt cast, pressure assisted pouring, or centrifugal cast.

**Removal:** The shell is hammered, media blasted, vibrated, waterjetted, or chemically dissolved (sometimes with liquid nitrogen) to release the casting. The sprue is cut off and recycled. The casting may then be cleaned up to remove signs of the casting process, usually by grinding.

## **Advantages of Investment casting**

Many Intricate forms with undercuts can be cast.

A very smooth surface is obtained with no parting line.

Dimensional accuracy is good.

Certain unmachinable parts can be cast to preplanned shape.

It may be used to replace die-casting where short runs are involved.

### **Disadvantages of Investment casting.**

This process is expensive, is usually limited to small casting, and presents some difficulties where cores are involved.

Holes cannot be smaller than 1/16 in. (1.6mm) and should be no deeper than about 1.5 times the diameter.

Investment castings require very long production-cycle times versus other casting processes.

This process is practically infeasible for high-volume manufacturing, due to its high cost and long cycle times.

Many of the advantages of the investment casting process can be achieved through other casting techniques if principles of thermal design and control are applied appropriately to existing processes that do not involve the shortcomings of investment castings.

### **Counter-gravity casting**

A variation on the gravity pouring technique is to fill the mold using a vacuum. A common form of this is called the Hitchiner process after the Hitchiner Manufacturing Company that invented the technique. In this technique, the mold has a downward fill pipe that is lowered into the melt. A vacuum draws the melt into the cavity; when the important parts have solidified, the vacuum is released, and the unused material leaves the mold. The technique can use substantially less material than gravity pouring because the sprue and some gating need not solidify.

This technique is more metal efficient than traditional pouring because less material solidifies in the gating system. Gravity pouring only has a 15 to 50% metal yield compared to 60 to 95% for counter-gravity pouring. There is also less turbulence, so the gating system can be simplified since it does not have to control turbulence. The metal is drawn from below the top of the pool, so the metal is free from dross and slag (which are lower density (lighter) and float to the top of the pool). The pressure differential helps the metal flow into every intricacy of the mold. Finally, lower temperatures can be used, which improves the grain structure.

This process is also used to cast refractory ceramics under the term vacuum casting.

## **Vacuum Pressure Casting**

Vacuum pressure casting (VPC) uses gas pressure and a vacuum to improve the quality of the casting and minimize porosity. Typically VPC casting machines consist of an upper and a lower chamber. The upper chamber or melting chamber housing the crucible, and the lower casting chamber housing the investment mould. Both chambers are connected via a small hole containing a stopper. A vacuum is pulled in the lower chamber, while pressure is applied in the upper, and then the stopper is removed. This creates the greatest pressure differential to fill the molds.

Investment casting is used with almost any castable metal, however aluminium alloys, copper alloys, and steel are the most common. In industrial usage the size limits are 3 g (0.1 oz) to about 5 kg (11 lb). The cross-sectional limits are 0.6 mm (0.024 in) to 75 mm (3.0 in). Typical tolerances are 0.1 mm for the first 25 mm (0.005 in for the first inch) and 0.02 mm for the each additional centimeter (0.002 in for each additional inch). A standard surface finish is 1.3–4 micrometres (50–125  $\mu\text{in}$ ) RMS.

The advantages of investment casting are:

Excellent surface finish

High dimensional accuracy

Extremely intricate parts are castable

Almost any metal can be cast

No flash or parting lines

The main disadvantage is the overall cost. Some of the reasons for the high cost include specialized equipment, costly refractories and binders, many operations to make a mould, a lot of labor is needed and occasional minute defects. However, the cost is still less than producing the same part by machining from bar stock; for example, gun manufacturing has moved to investment casting to lower costs of producing pistols.

## **History**

The history of lost-wax casting dates back thousands of years. Its earliest use was for idols, ornaments and jewellery, using natural beeswax for patterns, clay for the moulds and manually operated bellows for stoking furnaces. Examples have been found across the world in Pakistan's Harappan Civilisation (2500–2000 BC) idols, Egypt's tombs of Tutankhamun (1333–1324 BC), Mesopotamia, Aztec and Mayan Mexico, and the Benin civilization in Africa where the process produced detailed artwork of copper, bronze and gold.

The earliest known text that describes the investment casting process (*Schedula Diversarum Artium*) was written around 1100 A.D. by Theophilus Presbyter, a monk who described various manufacturing processes, including the recipe for parchment. This book was used by sculptor and goldsmith Benvenuto Cellini (1500–1571), who detailed in his autobiography the investment casting process he used for the Perseus with the Head of Medusa sculpture that stands in the Loggia dei Lanzi in Florence, Italy.

Investment casting came into use as a modern industrial process in the late 19th century, when dentists began using it to make crowns and inlays, as described by Barnabas Frederick Philbrook of Council Bluffs, Iowa in 1897. Its use was accelerated by William H. Taggart of Chicago, whose 1907 paper described his development of a technique. He also formulated a wax pattern compound of excellent properties, developed an investment material, and invented an air-pressure casting machine.

In the 1940s, World War II increased the demand for precision net shape manufacturing and specialized alloys that could not be shaped by traditional methods, or that required too much machining.

Industry turned to investment casting. After the war, its use spread to many commercial and industrial applications that used complex metal parts.

## **Applications**

Investment casting is used in the aerospace and power generation industries to produce turbine blades with complex shapes or cooling systems. Blades produced by investment casting can

include single-crystal (SX), directionally solidified (DS), or conventional equiaxed blades. Investment casting is also widely used by firearms manufacturers to fabricate firearm receivers, triggers, hammers, and other precision parts at low cost. Other industries that use standard investment-cast parts include military, medical, commercial and automotive.

## CHAPTER 7

### **Evaporative-pattern casting**

Evaporative-pattern casting is a type of casting process that uses a pattern made from a material that will evaporate when the molten metal is poured into the molding cavity. The most common evaporative-pattern material used is polystyrene foam.

The two major evaporative-pattern casting processes are:

#### **Lost-foam casting**

#### **Full-mold casting**

The main difference is that lost-foam casting uses an unbonded sand and full-mold casting uses a bonded sand (or green sand). Because this difference is quite small there is much overlap in the terminology. Non-proprietary terms that have been used to describe these processes include: cavityless casting, evaporative foam casting, foam vaporization casting, lost pattern casting, the castral process, and expanded polystyrene molding. Proprietary terms included Styro-cast, Foam Cast, Replicast, and Policast.

Lost-foam casting (LFC) is a type of evaporative-pattern casting process that is similar to investment casting except foam is used for the pattern instead of wax. This process takes advantage of the low boiling point of foam to simplify the investment casting process by removing the need to melt the wax out of the mold.

#### **Process**

First, a pattern is made from polystyrene foam, which can be done many different ways. For small volume runs the pattern can be hand cut or machined from a solid block of foam; if the geometry is simple enough it can even be cut using a hot-wire foam cutter. If the volume is large,

then the pattern can be mass-produced by a process similar to injection molding. Pre-expanded beads of polystyrene are injected into a preheated aluminum mold at low pressure. Steam is then applied to the polystyrene which causes it to expand more to fill the die. The final pattern is approximately 97.5% air and 2.5% polystyrene. Pre-made pouring basins, runners, and risers can be hot glued to the pattern to finish it.

Polystyrene (PS) is a synthetic aromatic polymer made from the monomer styrene, a liquid petrochemical. Polystyrene can be rigid or foamed. General purpose polystyrene is clear, hard and brittle. It is a very inexpensive resin per unit weight. It is a rather poor barrier to oxygen and water vapor and has a relatively low melting point. Polystyrene is one of the most widely used plastics, the scale of its production being several billion kilograms per year. Polystyrene can be naturally transparent, but can be colored with colorants. Uses include protective packaging (such as packing peanuts and CD and DVD cases), containers (such as "clamshells"), lids, bottles, trays, tumblers, and disposable cutlery.

As a thermoplastic polymer, polystyrene is in a solid (glassy) state at room temperature but flows if heated above about 100 °C, its glass transition temperature. It becomes rigid again when cooled. This temperature behavior is exploited for extrusion, and also for molding and vacuum forming, since it can be cast into molds with fine detail.

It is very slow to biodegrade and therefore a focus of controversy, since it is often abundant as a form of litter in the outdoor environment, particularly along shores and waterways especially in its foam form.

Next, the foam cluster is coated with ceramic investment, also known as the refractory coating, via dipping, brushing, spraying or flow coating. This coating creates a barrier between the smooth foam surface and the coarse sand surface. Secondly it controls permeability, which allows the gas created by the vaporized foam pattern to escape through the coating and into the sand. Controlling permeability is a crucial step to avoid sand erosion. Finally, it forms a barrier so that molten metal does not penetrate or cause sand erosion during pouring. After the coating dries, the cluster is placed into a flask and backed up with un-bonded sand. The sand is then compacted using a vibration table. Once compacted, the mold is ready to be poured. Automatic



pouring is commonly used in LFC, as the pouring process is significantly more critical than in conventional foundry practice.

There is no bake-out phase, as for lost-wax. The melt is poured directly into the foam-filled mould, burning out the foam as it pours. As the foam is of low density, the waste gas produced by this is relatively small and can escape through mould permeability, as for the usual outgassing control.

Commonly cast metals include cast irons, aluminium alloys, steels, and nickel alloys; less frequently stainless steels and copper alloys are also cast. The size range is from 0.5 kg (1.1 lb) to several tonnes (tons). The minimum wall thickness is 2.5 mm (0.098 in) and there is no upper limit. Typical surface finishes are from 2.5 to 25  $\mu\text{m}$  (100 to 1000  $\mu\text{in}$ ) RMS. Typical linear tolerances are  $\pm 0.005$  mm/mm (0.005 in/in).

## **Advantages And Disadvantages**

This casting process is advantageous for very complex castings that would regularly require cores. It is also dimensionally accurate, maintains an excellent surface finish, requires no draft, and has no parting lines so no flash is formed. As compared to investment casting, it is cheaper because it is a simpler process and the foam is cheaper than the wax. Risers are not usually required due to the nature of the process; because the molten metal vaporizes the foam the first metal into the mold cools more quickly than the rest, which results in natural directional solidification. Foam is easy to manipulate, carve and glue, due to its unique properties. The flexibility of LFC often allows for consolidating the parts into one integral component; other forming processes would require the production of one or more parts to be assembled.

The two main disadvantages are that pattern costs can be high for low volume applications and the patterns are easily damaged or distorted due to their low strength. If a die is used to create the patterns there is a large initial cost.

## **History**

Lost-foam casting was invented in 1964 by M.C. Flemmings. Public recognition of the benefits of LFC was made by General Motors in the mid 1980s when it announced its new car line,

Saturn, would utilize LFC for production of all engine blocks, cylinder heads, crankshafts, differential carriers, and transmission cases.

## **Full-mold casting**

Full-mold casting is an evaporative-pattern casting process which is a combination of sand casting and lost-foam casting. It uses an expanded polystyrene foam pattern which is then surrounded by sand, much like sand casting. The metal is then poured directly into the mold, which vaporizes the foam upon contact.

### **Process**

First, a pattern is made from polystyrene foam, which can be done many different ways. For small volume runs the pattern can be hand cut or machined from a solid block of foam; if the geometry is simple enough it can even be cut using a hot-wire foam cutter. If the volume is large, then the pattern can be mass-produced by a process similar to injection molding. Pre-expanded beads of polystyrene are injected into a preheated aluminium mold at low pressure. Steam is then applied to the polystyrene which causes it to expand more to fill the die. The final pattern is approximately 97.5% air and 2.5% polystyrene. Once the pattern is made pre-made pouring basins, runners, and risers can be hot glued to form the final pattern.

The pattern is then coated with a refractory material. The coated pattern is then placed in a flask and packed carefully with green sand or a chemically bonded sand. Finally, the molten metal is poured into the mold, which vaporizes the foam allowing the metal to fill the entire mold. The casting is allowed to cool and then dumped out of the flask ready to use. The sand does not need to be reprocessed so it can be directly reused.

The minimum wall thickness for a full-mold casting is 2.5 mm (0.10 in). Typical dimensional tolerances are 0.3% and typical surface finishes are from 2.5 to 25  $\mu\text{m}$  (100 to 1000  $\mu\text{in}$ ) RMS. The size range is from 400 g (0.88 lb) to several tonnes (tons).

Full-mold casting is often used to produce cylinder heads, engine blocks, pump housings, automotive brake components, and manifolds. Commonly employed materials include aluminium, iron, steel, nickel alloys, and copper alloys

Expanded polystyrene (EPS) is a rigid and tough, closed-cell foam. It is usually white and made of pre-expanded polystyrene beads. EPS is used for disposable trays, plates, bowls and cups; and for carry-out food packaging (including the hinged lid containers popularly known as "clam shells"). Other uses include molded sheets for building insulation and packing material ("peanuts") for cushioning fragile items inside boxes. Sheets are commonly packaged as rigid panels (size 4 by 8 or 2 by 8 feet in the United States), which are also known as "bead-board".

Due to its technical properties such as low weight, rigidity, and formability, EPS can be used in a wide range of different applications. Its market value is likely to rise to more than US\$15 billion until 2020. Thermal conductivity is measured according to EN 12667. Typical values range from 0.032 to 0.038 W/(m·K) depending on the density of the EPS board. The value of 0.038 W/(m·K) was obtained at 15 kg/m<sup>3</sup> while the value of 0.032 W/(m·K) was obtained at 40 kg/m<sup>3</sup> according to the data sheet of K-710 from StyroChem Finland. Adding fillers (graphites, aluminium, or carbons) has recently allowed the thermal conductivity of EPS to reach around 0.030–0.034 (as low as 0.029) and as such has a grey/black color which distinguishes it from standard EPS. Several EPS producers have produced a variety of these increased thermal resistance EPS usage for this product in the UK & EU.

Water vapor diffusion resistance ( $\mu$ ) of EPS is around 30–70.

ICC-ES (International Code Council Evaluation Service) requires EPS boards used in building construction meet ASTM C578 requirements. One of these requirements is that the oxygen index of EPS as measured by ASTM D2863 be greater than 24 volume %. Typical EPS has an oxygen index of around 18 volume %; thus, a flame retardant such as HBCD (hexabromocyclododecane), is added to styrene or polystyrene during the formation of EPS.

The boards containing HBCD when tested in a tunnel using test method UL 723 or ASTM E84 will have a flame spread index of less than 25 and a smoke-developed index of less than 450. ICC-ES requires the use of a 15-minute thermal barrier when EPS boards are used inside of a building.

According to EPS-IA ICF organization, the typical density of EPS used for insulated concrete forms is 1.35 to 1.80 pcf. This is either Type II or Type IX EPS according to ASTM C578. EPS blocks or boards used in building construction are commonly cut using hot wires.

## **Advantages And Disadvantages**

This casting process is advantageous for very complex castings, that would regularly require cores. It is also dimensionally accurate, requires no draft, and has no parting lines so no flash is formed. As compared to investment casting, it is cheaper because it is a simpler process and the foam is cheaper than the wax. Risers are not usually required due to the nature of the process; because the molten metal vaporizes the foam the first metal into the mold cools more quickly than the rest, which results in natural directional solidification.

## **Directional Solidification**

Directional solidification and progressive solidification describe types of solidification within castings. Directional solidification describes solidification that occurs from farthest end of the casting and works its way towards the sprue. Progressive solidification, also known as parallel solidification, is solidification that starts at the walls of the casting and progresses perpendicularly from that surface.

Most metals and alloys shrink as the material changes from a liquid state to a solid state. Therefore, if liquid material is not available to compensate for this shrinkage a shrinkage defect forms. When progressive solidification dominates over directional solidification a shrinkage defect will form.

The geometrical shape of the mold cavity has direct effect on progressive and directional solidification. At the end of tunnel type geometries divergent heat flow occurs, which causes that area of the casting to cool faster than surrounding areas; this is called an end effect. Large cavities do not cool as quickly as surrounding areas because there is less heat flow; this is called a riser effect. Also note that corners can create divergent or convergent (also known as hot spots) heat flow areas.

In order to induce directional solidification chills, risers, insulating sleeves, control of pouring rate, and pouring temperature can be utilized.

Directional solidification can be used as a purification process. Since most impurities will be more soluble in the liquid than in the solid phase during solidification, impurities will be

"pushed" by the solidification front, causing much of the finished casting to have a lower concentration of impurities than the feedstock material, while the last solidified metal will be enriched with impurities. This last part of the metal can be scrapped or recycled. The suitability of directional solidification in removing a specific impurity from a certain metal depends on the partition coefficient of the impurity in the metal in question, as described by the Scheil equation. Directional solidification is frequently employed as a purification step in the production of multicrystalline silicon for solar cells.

The two main disadvantages are that pattern costs can be high for low volume applications and the patterns are easily damaged or distorted due to their low strength. If a die is used to create the patterns there is a large initial cost.

## **History**

The first patent for an evaporative-pattern casting process was filed in April 1956, by H.F. Shroyer. He patented the use of foam patterns embedded in traditional green sand for metal casting.

## **CHAPTER - 8**

### **Permanent mold casting**

Non-expendable mold casting differs from expendable processes in that the mold need not be reformed after each production cycle. This technique includes at least four different methods: permanent, die, centrifugal, and continuous casting. This form of casting also results in improved repeatability in parts produced and delivers Near Net Shape results.

Permanent mold casting is metal casting process that employs reusable molds ("permanent molds"), usually made from metal. The most common process uses gravity to fill the mold, however gas pressure or a vacuum are also used. A variation on the typical gravity casting process, called slush casting, produces hollow castings. Common casting metals are aluminum, magnesium, and copper alloys. Other materials include tin, zinc, and lead alloys and iron and steel are also cast in graphite molds.

Typical parts include gears, splines, wheels, gear housings, pipe fittings, fuel injection housings, and automotive engine pistons.

A **gear** or cogwheel is a rotating machine part having cut teeth, or cogs, which mesh with another toothed part in order to transmit torque, in most cases with teeth on the one gear of identical shape, and often also with that shape (or at least width) on the other gear. Two or more gears working in tandem are called a transmission and can produce a mechanical advantage through a gear ratio and thus may be considered a simple machine. Geared devices can change the speed, torque, and direction of a power source. The most common situation is for a gear to mesh with another gear; however, a gear can also mesh with a non-rotating toothed part, called a rack, thereby producing translation instead of rotation.

The gears in a transmission are analogous to the wheels in a crossed belt pulley system. An advantage of gears is that the teeth of a gear prevent slipping.

When two gears of unequal number of teeth are combined, a mechanical advantage is produced, with the rotational speeds and the torques of the two gears differing in a simple inverse relationship.

In transmissions which offer multiple gear ratios, such as bicycles and cars, the term gear, as in first gear, refers to a gear ratio rather than an actual physical gear. The term is used to describe similar devices even when the gear ratio is continuous rather than discrete, or when the device does not actually contain any gears, as in a continuously variable transmission.

The earliest known reference to gears was circa A.D. 50 by Hero of Alexandria, but they can be traced back to the Greek mechanics of the Alexandrian school in the 3rd century B.C. and were greatly developed by the Greek polymath Archimedes (287–212 B.C.). The Antikythera mechanism is an example of a very early and intricate geared device, designed to calculate astronomical positions. Its time of construction is now estimated between 150 and 100 BC.

**Splines** are ridges or teeth on a drive shaft that mesh with grooves in a mating piece and transfer torque to it, maintaining the angular correspondence between them.

For instance, a gear mounted on a shaft might use a male spline on the shaft that matches the female spline on the gear. The splines on the pictured drive shaft match with the female splines

in the center of the clutch plate, while the smooth tip of the axle is supported in the pilot bearing in the flywheel. An alternative to splines is a keyway and key, though splines provide a longer fatigue life.

A **wheel** is a circular component that is intended to rotate on an axial bearing. The wheel is one of the main components of the wheel and axle which is one of the six simple machines. Wheels, in conjunction with axles, allow heavy objects to be moved easily facilitating movement or transportation while supporting a load, or performing labor in machines. Wheels are also used for other purposes, such as a ship's wheel, steering wheel, potter's wheel and flywheel.

Common examples are found in transport applications. A wheel greatly reduces friction by facilitating motion by rolling together with the use of axles. In order for wheels to rotate, a moment needs to be applied to the wheel about its axis, either by way of gravity, or by the application of another external force or torque.

The **gear housing** is the casing that surrounds the mechanical components of a gear box. It provides mechanical support for the moving components, a mechanical protection from the outside world for those internal components, and a fluid-tight container to hold the lubricant that bathes those components.

## **Process**

There are four main types of permanent mold casting: gravity, slush, low-pressure, and vacuum.

### **Gravity process**

The gravity process begins by preheating the mold to 150-200 °C (300-400 °F) to ease the flow and reduce thermal damage to the casting. The mold cavity is then coated with a refractory material or a mold wash, which prevents the casting from sticking to the mold and prolongs the mold life. Any sand or metal cores are then installed and the mold is clamped shut. Molten metal is then poured into the mold. Soon after solidification the mold is opened and the casting removed to reduce chances of hot tears. The process is then started all over again, but preheating is not required because the heat from the previous casting is adequate and the refractory coating should last several castings. Because this process is usually carried out on large production run

workpieces automated equipment is used to coat the mold, pour the metal, and remove the casting.

The metal is poured at the lowest practical temperature in order to minimize cracks and porosity. The pouring temperature can range greatly depending on the casting material; for instance zinc alloys are poured at approximately 700 °F (371 °C), while gray iron is poured at approximately 2,500 °F (1,370 °C).

## **Mold**

Molds for the casting process consist of two halves. Casting molds are usually formed from gray cast iron because it has about the best thermal fatigue resistance, but other materials include steel, bronze, and graphite. These metals are chosen because of their resistance to erosion and thermal fatigue. They are usually not very complex because the mold offers no collapsibility to compensate for shrinkage. Instead the mold is opened as soon as the casting is solidified, which prevents hot tears. Cores can be used and are usually made from sand or metal.

As stated above, the mold is heated prior to the first casting cycle and then used continuously in order to maintain as uniform a temperature as possible during the cycles. This decreases thermal fatigue, facilitates metal flow, and helps control the cooling rate of the casting metal.

Venting usually occurs through the slight crack between the two mold halves, but if this is not enough then very small vent holes are used. They are small enough to let the air escape but not the molten metal. A riser must also be included to compensate for shrinkage. This usually limits the yield to less than 60%.

Mechanical ejectors in the form of pins are used when coatings are not enough to remove casts from the molds. These pins are placed throughout the mold and usually leave small round impressions on the casting.

## **Slush**

Slush casting is a variant of permanent molding casting to create a hollow casting or hollow cast. In the process the material is poured into the mold and allowed to cool until a shell of material forms in the mold. The remaining liquid is then poured out to leave a hollow shell. The resulting



casting has good surface detail but the wall thickness can vary. The process is usually used to cast ornamental products, such as candlesticks, lamp bases, and statuary, from low-melting-point materials. A similar technique is used to make hollow chocolate figures for Easter and Christmas.

The method was developed by William Britain in 1893 for the production of lead toy soldiers. It uses less material than solid casting, and results in a lighter and less expensive product. Hollow cast figures generally have a small hole where the excess liquid was poured out.

## **Low-pressure**

Low-pressure permanent mold (LPPM) casting uses a gas at low pressure, usually between 3 and 15 psig (20 to 100 kPag) to push the molten metal into the mold cavity. The pressure is applied to the top of the pool of liquid, which forces the molten metal up a refractory pouring tube and finally into the bottom of the mold. The pouring tube extends to the bottom of the ladle so that the material being pushed into the mold is exceptionally clean. No risers are required because the applied pressure forces molten metal in to compensate for shrinkage. Yields are usually greater than 85% because there is no riser and any metal in the pouring tube just falls back into the ladle for reuse.

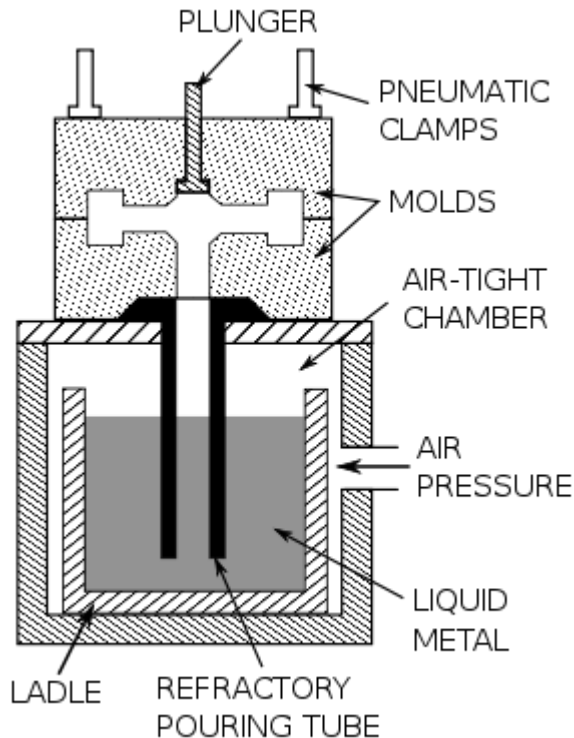

The vast majority of LPPM casting are from aluminum and magnesium, but some are copper alloys. Advantages include very little turbulence when filling the mold because of the constant pressure, which minimizes gas porosity and dross formation. Mechanical properties are about 5% better than gravity permanent mold castings. The disadvantage is that cycles times are longer than gravity permanent mold castings.

## **Vacuum**

Vacuum permanent mold casting retains all of the advantages of LPPM casting, plus the dissolved gases in the molten metal are minimized and molten metal cleanliness is even better. The process can handle thin-walled profiles and gives an excellent surface finish. Mechanical properties are usually 10 to 15% better than gravity permanent mold castings. The process is limited in weight to 0.2 to 5 kg (0.44 to 11 lb).

## **Advantages And Disadvantages**

The main advantages are the reusable mold, good surface finish, and good dimensional accuracy. Typical tolerances are 0.4 mm for the first 25 mm (0.015 in for the first inch) and 0.02 mm for

each additional centimeter (0.002 in per in); if the dimension crosses the parting line add an additional 0.25 mm (0.0098 in). Typical surface finishes are 2.5 to 7.5  $\mu\text{m}$  (100–250  $\mu\text{in}$ ) RMS. A draft of 2 to 3° is required. Wall thicknesses are limited to 3 to 50 mm (0.12 to 2.0 in). Typical part sizes range from 100 g to 75 kg (several ounces to 150 lb). Other advantages include the ease of inducing directional solidification by changing the mold wall thickness or by heating or cooling portions of the mold. The fast cooling rates created by using a metal mold results in a finer grain structure than sand casting. Retractable metal cores can be used to create undercuts while maintaining a quick action mold.

There are three main disadvantages: high tooling cost, limited to low-melting-point metals, and short mold life. The high tooling costs make this process uneconomical for small production runs. When the process is used to cast steel or iron the mold life is extremely short. For lower melting point metals the mold life is longer but thermal fatigue and erosion usually limit the life to 10,000 to 120,000 cycles. The mold life is dependent on four factors: the mold material, the pouring temperature, the mold temperature, and the mold configuration. The pouring temperature is dependent on the casting metal, but the higher the pouring temperature the shorter the mold life. A high pouring temperature can also induce shrinkage problems and create longer cycle times. If the mold temperature is too low misruns are produced, but if the mold temperature is too high then the cycle time is prolonged and mold erosion is increased. Large differences in section thickness in the mold or casting can decrease mold life as well.

## **CHAPTER - 9**

### **Die Casting**

Die casting is a metal casting process that is characterized by forcing molten metal under high pressure into a mold cavity. The mold cavity is created using two hardened tool steel dies which have been machined into shape and work similarly to an injection mold during the process. Most die castings are made from non-ferrous metals, specifically zinc, copper, aluminium, magnesium, lead, pewter and tin based alloys. Depending on the type of metal being cast, a hot- or cold-chamber machine is used.

The casting equipment and the metal dies represent large capital costs and this tends to limit the process to high volume production. Manufacture of parts using die casting is relatively simple, involving only four main steps, which keeps the incremental cost per item low. It is especially suited for a large quantity of small to medium sized castings, which is why die casting produces more castings than any other casting process. Die castings are characterized by a very good surface finish (by casting standards) and dimensional consistency.

Two variants are pore-free die casting, which is used to eliminate gas porosity defects; and direct injection die casting, which is used with zinc castings to reduce scrap and increase yield.

## **History**

Die casting equipment was invented in 1838 for the purpose of producing movable type for the printing industry. The first die casting-related patent was granted in 1849 for a small hand operated machine for the purpose of mechanized printing type production. In 1885, Otto Mergenthaler invented the linotype machine, an automated type casting device which became the prominent type of equipment in the publishing industry. The Soss die-casting machine, manufactured in Brooklyn, NY was the first machine to be sold in the open market in North America. Other applications grew rapidly, with die casting facilitating the growth of consumer goods and appliances by making affordable the production of intricate parts in high volumes. In 1966, General Motors released the Acurad process.

## **Cast Metals**

The main die casting alloys are: zinc, aluminium, magnesium, copper, lead, and tin; although uncommon, ferrous die casting is also possible. Specific die casting alloys include: ZAMAK; zinc aluminium; aluminium to, e.g. The Aluminum Association (AA) standards: AA 380, AA 384, AA 386, AA 390; and AZ91D magnesium. The following is a summary of the advantages of each alloy:

**Zinc:** the easiest metal to cast; high ductility; high impact strength; easily plated; economical for small parts; promotes long die life.

**Aluminium:** lightweight; high dimensional stability for complex shapes and thin walls; good corrosion resistance; good mechanical properties; high thermal and electrical conductivity; retains strength at high temperatures.

Magnesium: the easiest metal to machine; excellent strength-to-weight ratio; lightest alloy commonly die cast.

Copper: high hardness; high corrosion resistance; highest mechanical properties of alloys die cast; excellent wear resistance; excellent dimensional stability; strength approaching that of steel parts.

Lead and tin: high density; extremely close dimensional accuracy; used for special forms of corrosion resistance. Such alloys are not used in foodservice applications for public health reasons. Type metal, an alloy of Lead, Tin and Antimony (with sometimes traces of Copper) is used for casting hand set type in letterpress printing and hot foil blocking. Traditionally cast in hand jerk moulds now predominantly die cast after the industrialisation of the type foundries. Around 1900 the slug casting machines came onto the market and added further automation with sometimes dozens of casting machines at one newspaper office.

Maximum weight limits for aluminium, brass, magnesium, and zinc castings are approximately 70 pounds (32 kg), 10 lb (4.5 kg), 44 lb (20 kg), and 75 lb (34 kg), respectively.

The material used defines the minimum section thickness and minimum draft required for a casting as outlined in the table below. The thickest section should be less than 13 mm (0.5 in), but can be greater.

<b>Metal</b>	<b>Minimum section</b>	<b>Minimum draft</b>
Aluminium alloys	0.89 mm (0.035 in)	1:100 (0.6°)
Brass and bronze	1.27 mm (0.050 in)	1:80 (0.7°)
Magnesium alloys	1.27 mm (0.050 in)	1:100 (0.6°)
Zinc alloys	0.63 mm (0.025 in)	1:200 (0.3°)

## Equipment

There are two basic types of die casting machines: hot-chamber machines and cold-chamber machines. These are rated by how much clamping force they can apply. Typical ratings are between 400 and 4,000 st (2,500 and 25,000 kg).

### Hot-chamber machines

Hot-chamber machines, also known as gooseneck machines, rely upon a pool of molten metal to feed the die. At the beginning of the cycle the piston of the machine is retracted, which allows the molten metal to fill the "gooseneck". The pneumatic or hydraulic powered piston then forces this metal out of the gooseneck into the die. The advantages of this system include fast cycle times (approximately 15 cycles a minute) and the convenience of melting the metal in the casting machine. The disadvantages of this system are that high-melting point metals cannot be utilized and aluminium cannot be used because it picks up some of the iron while in the molten pool. Due to this, hot-chamber machines are primarily used with zinc, tin, and lead based alloys.

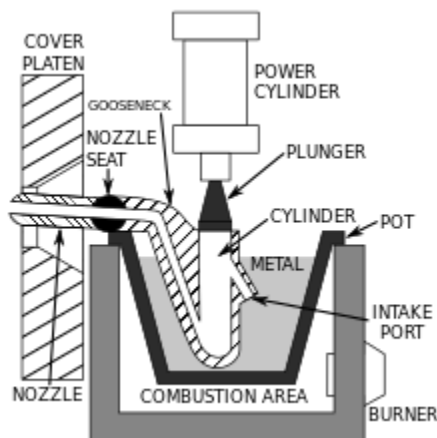

### Cold - Chamber Machines

These are used when the casting alloy cannot be used in hot-chamber machines; these include aluminium, zinc alloys with a large composition of aluminium, magnesium and copper. The process for these machines start with melting the metal in a separate furnace. Then a precise amount of molten metal is transported to the cold-chamber machine where it is fed into an unheated shot chamber (or injection cylinder). This shot is then driven into the die by a hydraulic

or mechanical piston. This biggest disadvantage of this system is the slower cycle time due to the need to transfer the molten metal from the furnace to the cold-chamber machine.

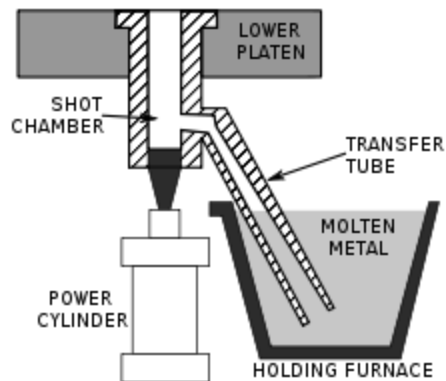

## Dies

Two dies are used in die casting; one is called the "cover die half" and the other the "ejector die half". Where they meet is called the parting line. The cover die contains the sprue (for hot-chamber machines) or shot hole (for cold-chamber machines), which allows the molten metal to flow into the dies; this feature matches up with the injector nozzle on the hot-chamber machines or the shot chamber in the cold-chamber machines. The ejector die contains the ejector pins and usually the runner, which is the path from the sprue or shot hole to the mold cavity. The cover die is secured to the stationary, or front, platen of the casting machine, while the ejector die is attached to the movable platen. The mold cavity is cut into two cavity inserts, which are separate pieces that can be replaced relatively easily and bolt into the die halves.

The dies are designed so that the finished casting will slide off the cover half of the die and stay in the ejector half as the dies are opened. This assures that the casting will be ejected every cycle because the ejector half contains the ejector pins to push the casting out of that die half. The ejector pins are driven by an ejector pin plate, which accurately drives all of the pins at the same time and with the same force, so that the casting is not damaged. The ejector pin plate also retracts the pins after ejecting the casting to prepare for the next shot. There must be enough ejector pins to keep the overall force on each pin low, because the casting is still hot and can be damaged by excessive force. The pins still leave a mark, so they must be located in places where these marks will not hamper the casting's purpose.

Other die components include cores and slides. Cores are components that usually produce holes or opening, but they can be used to create other details as well. There are three types of cores: fixed, movable, and loose. Fixed cores are ones that are oriented parallel to the pull direction of the dies (i.e. the direction the dies open), therefore they are fixed, or permanently attached to the die. Movable cores are ones that are oriented in any other way than parallel to the pull direction. These cores must be removed from the die cavity after the shot solidifies, but before the dies open, using a separate mechanism. Slides are similar to movable cores, except they are used to form undercut surfaces. The use of movable cores and slides greatly increases the cost of the dies. Loose cores, also called pick-outs, are used to cast intricate features, such as threaded holes. These loose cores are inserted into the die by hand before each cycle and then ejected with the part at the end of the cycle. The core then must be removed by hand. Loose cores are the most expensive type of core, because of the extra labor and increased cycle time. Other features in the dies include water-cooling passages and vents along the parting lines. These vents are usually wide and thin (approximately 0.13 mm or 0.005 in) so that when the molten metal starts filling them the metal quickly solidifies and minimizes scrap. No risers are used because the high pressure ensures a continuous feed of metal from the gate.

The most important material properties for the dies are thermal shock resistance and softening at elevated temperature; other important properties include hardenability, machinability, heat checking resistance, weldability, availability (especially for larger dies), and cost. The longevity of a die is directly dependent on the temperature of the molten metal and the cycle time. The dies used in die casting are usually made out of hardened tool steels, because cast iron cannot withstand the high pressures involved, therefore the dies are very expensive, resulting in high start-up costs. Metals that are cast at higher temperatures require dies made from higher alloy steels.

## **Process**

The following are the four steps in traditional die casting, also known as high-pressure die casting, these are also the basis for any of the die casting variations: die preparation, filling, ejection, and shakeout. The dies are prepared by spraying the mold cavity with lubricant. The lubricant both helps control the temperature of the die and it also assists in the removal of the casting. The dies are then closed and molten metal is injected into the dies under high pressure;



between 10 and 175 megapascals (1,500 and 25,400 psi). Once the mold cavity is filled, the pressure is maintained until the casting solidifies. The dies are then opened and the shot (shots are different from castings because there can be multiple cavities in a die, yielding multiple castings per shot) is ejected by the ejector pins. Finally, the shakeout involves separating the scrap, which includes the gate, runners, sprues and flash, from the shot. This is often done using a special trim die in a power press or hydraulic press. Other methods of shaking out include sawing and grinding. A less labor-intensive method is to tumble shots if gates are thin and easily broken; separation of gates from finished parts must follow. This scrap is recycled by remelting it. The yield is approximately 67%.

The high-pressure injection leads to a quick fill of the die, which is required so the entire cavity fills before any part of the casting solidifies. In this way, discontinuities are avoided, even if the shape requires difficult-to-fill thin sections. This creates the problem of air entrapment, because when the mold is filled quickly there is little time for the air to escape. This problem is minimized by including vents along the parting lines, however, even in a highly refined process there will still be some porosity in the center of the casting.

Most die casters perform other secondary operations to produce features not readily castable, such as tapping a hole, polishing, plating, buffing, or painting.

## **Inspection**

After the shakeout of the casting it is inspected for defects. The most common defects are misruns and cold shuts. These defects can be caused by cold dies, low metal temperature, dirty metal, lack of venting, or too much lubricant. Other possible defects are gas porosity, shrinkage porosity, hot tears, and flow marks. Flow marks are marks left on the surface of the casting due to poor gating, sharp corners, or excessive lubricant.

## **Lubricants**

Water-based lubricants, called emulsions, are the most commonly used type of lubricant, because of health, environmental, and safety reasons. Unlike solvent-based lubricants, if water is properly treated to remove all minerals from it, it will not leave any by-product in the dies. If the water is not properly treated, then the minerals can cause surface defects and discontinuities. There are

four types of water-based lubricants: oil in water, water in oil, semi-synthetic, and synthetic. Oil in water is the best, because when the lubricant is applied the water cools the die surface by evaporating while depositing the oil, which helps release the shot. A common mixture for this type of lubricants is thirty parts water to one part oil, however in extreme cases a ratio of 100:1 is used.

Oils that are used include heavy residual oil (HRO), animal fats, vegetable fats, and synthetic fats. HROs are gelatinous at room temperature, but at the high temperatures found in die casting, they form a thin film. Other substances are added to control the emulsions viscosity and thermal properties; these include graphite, aluminium, and mica. Other chemical additives are used to inhibit rusting and oxidation. Emulsifiers are added to water-based lubricants, so that oil based additives can be mixed into the water; these include soap, alcohol esters, and ethylene oxides.

Historically, solvent-based lubricants, such as diesel fuel and kerosene, were commonly used. These were good at releasing the part from the dies, but a small explosion occurred during each shot, which led to a build-up of carbon on the mold cavity walls. However, they were easier to apply evenly than water-based lubricants.

Advantages and disadvantages

Advantages of die casting:

Excellent dimensional accuracy (dependent on casting material, but typically 0.1 mm for the first 2.5 cm (0.005 inch for the first inch) and 0.02 mm for each additional centimeter (0.002 inch for each additional inch).

Smooth cast surfaces (Ra 1–2.5 micrometres or 0.04–0.10 thou rms).

Thinner walls can be cast as compared to sand and permanent mold casting (approximately 0.75 mm or 0.030 in).

Inserts can be cast-in (such as threaded inserts, heating elements, and high strength bearing surfaces).

Reduces or eliminates secondary machining operations.

Rapid production rates.

Casting tensile strength as high as 415 megapascals (60 ksi).

Casting of low fluidity metals.

The main disadvantage to die casting is the very high capital cost. Both the casting equipment required and the dies and related components are very costly, as compared to most other casting processes. Therefore to make die casting an economic process a large production volume is needed. Other disadvantages are that the process is limited to high-fluidity metals, and casting weights must be between 30 grams (1 oz) and 10 kg (20 lb). In the standard die casting process the final casting will have a small amount of porosity. This prevents any heat treating or welding, because the heat causes the gas in the pores to expand, which causes micro-cracks inside the part and exfoliation of the surface.

## **Acurad**

Acurad was a die casting process developed by General Motors in the late 1950s and 1960s. The name is an acronym for accurate, reliable, and dense. It was developed to combine a stable fill and directional solidification with the fast cycle times of the traditional die casting process. The process pioneered four breakthrough technologies for die casting: thermal analysis, flow and fill modeling, heat treatable and high integrity die castings, and indirect squeeze casting.

The thermal analysis was the first done for any casting process. This was done by creating an electrical analog of the thermal system. A cross-section of the dies were drawn on Teledeltos paper and then thermal loads and cooling patterns were drawn onto the paper. Water lines were represented by magnets of various sizes. The thermal conductivity was represented by the reciprocal of the resistivity of the paper.

The Acurad system employed a bottom fill system that required a stable flow-front. Logical thought processes and trial and error were used because computerized analysis did not exist yet; however this modeling was the precursor to computerized flow and fill modeling.

The Acurad system was the first die casting process that could successfully cast low-iron aluminum alloys, such as A356 and A357. In a traditional die casting process these alloys would

solder to the die. Similarly, Acurad castings could be heat treated and meet the U.S. military specification MIL-A-21180.

Finally, the Acurad system employed a patented double shot piston design. The idea was to use a second piston (located within the primary piston) to apply pressure after the shot had partially solidified around the perimeter of the casting cavity and shot sleeve. While the system was not very effective, it did lead the manufacturer of the Acurad machines, Ube Industries, to discover that it was just as effective to apply sufficient pressure at the right time later in the cycle with the primary piston; this is indirect squeeze casting.

### **Pore-Free**

When no porosity is allowed in a cast part then the pore-free casting process is used. It is identical to the standard process except oxygen is injected into the die before each shot to purge any air from the mold cavity. This causes small dispersed oxides to form when the molten metal fills the die, which virtually eliminates gas porosity. An added advantage to this is greater strength. Unlike standard die castings, these castings can be heat treated and welded. This process can be performed on aluminium, zinc, and lead alloys.

### **Heated-Manifold Direct-Injection**

Heated-manifold direct-injection die casting, also known as direct-injection die casting or runnerless die casting, is a zinc die casting process where molten zinc is forced through a heated manifold and then through heated mini-nozzles, which lead into the molding cavity. This process has the advantages of lower cost per part, through the reduction of scrap (by the elimination of sprues, gates and runners) and energy conservation, and better surface quality through slower cooling cycles.

### **Semi-Solid**

Semi-solid die casting uses metal that is heated between its liquidus and solidus, so that it is "slushy". This allows for more complex parts and thinner walls.

## **CHAPTER - 10**

### **Semi-Solid Metal Casting**

Semi-solid metal casting (SSM) is a near net shape variant of die casting. The process is used with non-ferrous metals, such as aluminium, copper, and magnesium. The process combines the advantages of casting and forging. The process is named after the fluid property thixotropy, which is the phenomenon that allows this process to work. Simply, thixotropic fluids shear when the material flows, but thicken when standing. The potential for this type of process was first recognized in the early 1970s. There are four different processes: thixocasting, rheocasting, thixomolding, and SIMA.

Forging is a manufacturing process involving the shaping of metal using localized compressive forces. Forging is often classified according to the temperature at which it is performed: "cold", "warm", or "hot" forging. Forged parts can range in weight from less than a kilogram to 580 metric tons. Forged parts usually require further processing to achieve a finished part. Forging as an art form started with the desire to produce decorative objects from precious metals. Today, forging is a major world-wide industry that has significantly contributed to the development of man.

### **HISTORY**

Forging is one of the oldest known metalworking processes. Traditionally, forging was performed by a smith using hammer and anvil, and though the use of water power in the production and working of iron dates to the 12th century, the hammer and anvil are not obsolete. The smithy or forge has evolved over centuries to become a facility with engineered processes, production equipment, tooling, raw materials and products to meet the demands of modern industry.

In modern times, industrial forging is done either with presses or with hammers powered by compressed air, electricity, hydraulics or steam. These hammers may have reciprocating weights in the thousands of pounds. Smaller power hammers, 500 lb (230 kg) or less reciprocating weight, and hydraulic presses are common in art smithies as well. Some steam hammers remain

in use, but they became obsolete with the availability of the other, more convenient, power sources.

## **Advantages And Disadvantages**

Forging can produce a piece that is stronger than an equivalent cast or machined part. As the metal is shaped during the forging process, its internal grain deforms to follow the general shape of the part. As a result, the grain is continuous throughout the part, giving rise to a piece with improved strength characteristics.

Some metals may be forged cold, but iron and steel are almost always hot forged. Hot forging prevents the work hardening that would result from cold forging, which would increase the difficulty of performing secondary machining operations on the piece. Also, while work hardening may be desirable in some circumstances, other methods of hardening the piece, such as heat treating, are generally more economical and more controllable. Alloys that are amenable to precipitation hardening, such as most aluminium alloys and titanium, can be hot forged, followed by hardening.

Production forging involves significant capital expenditure for machinery, tooling, facilities and personnel. In the case of hot forging, a high-temperature furnace (sometimes referred to as the forge) is required to heat ingots or billets. Owing to the massiveness of large forging hammers and presses and the parts they can produce, as well as the dangers inherent in working with hot metal, a special building is frequently required to house the operation. In the case of drop forging operations, provisions must be made to absorb the shock and vibration generated by the hammer. Most forging operations use metal-forming dies, which must be precisely machined and carefully heat-treated to correctly shape the workpiece, as well as to withstand the tremendous forces involved.

## **PROCESSES**

There are many different kinds of forging processes available, however they can be grouped into three main classes:

Drawn out: length increases, cross-section decreases

Upset: length decreases, cross-section increases

Squeezed in closed compression dies: produces multidirectional flow

Common forging processes include: roll forging, swaging, cogging, open-die forging, impression-die forging, press forging, automatic hot forging and upsetting

## **Temperature**

All of the following forging processes can be performed at various temperatures, however they are generally classified by whether the metal temperature is above or below the recrystallization temperature. If the temperature is above the material's recrystallization temperature it is deemed hot forging; if the temperature is below the material's recrystallization temperature but above 30% of the recrystallization temperature (on an absolute scale) it is deemed warm forging; if below 30% of the recrystallization temperature (usually room temperature) then it is deemed cold forging. The main advantage of hot forging is that as the metal is deformed work hardening effects are negated by the recrystallization process. Cold forging typically results in work hardening of the piece.

## **Drop Forging**

Drop forging is a forging process where a hammer is raised and then "dropped" onto the workpiece to deform it according to the shape of the die. There are two types of drop forging: open-die drop forging and closed-die drop forging. As the names imply, the difference is in the shape of the die, with the former not fully enclosing the workpiece, while the latter does.

## **Open-Die Drop Forging**

Open-die drop forging (with two dies) of an ingot to be further processed into a wheel

Open-die forging is also known as smith forging. In open-die forging, a hammer strikes and deforms the workpiece, which is placed on a stationary anvil. Open-die forging gets its name from the fact that the dies (the surfaces that are in contact with the workpiece) do not enclose the workpiece, allowing it to flow except where contacted by the dies. Therefore the operator, or a robot, needs to orient and position the workpiece to get the desired shape. The dies are usually

flat in shape, but some have a specially shaped surface for specialized operations. For example, a die may have a round, concave, or convex surface or be a tool to form holes or be a cut-off tool.

Open die forgings can be worked into shapes which include discs, hubs, blocks, shafts (including step shafts or with flanges), sleeves, cylinders, flats, hexes, rounds, plate, and some custom shapes.

Open-die forging lends itself to short runs and is appropriate for art smithing and custom work. In some cases, open-die forging may be employed to rough-shape ingots to prepare them for subsequent operations. Open-die forging may also orient the grain to increase strength in the required direction.

Cogging is successive deformation of a bar along its length using an open-die drop forge. It is commonly used to work a piece of raw material to the proper thickness. Once the proper thickness is achieved the proper width is achieved via edging. Edging is the process of concentrating material using a concave shaped open die. The process is called edging because it is usually carried out on the ends of the workpiece. Fullering is a similar process that thins out sections of the forging using a convex shaped die. These processes prepare the workpieces for further forging processes.

## **Impression-Die Drop Forging**

Impression-die forging is also called closed-die forging. In impression-die forging, the metal is placed in a die resembling a mold, which is attached to the anvil. Usually, the hammer die is shaped as well. The hammer is then dropped on the workpiece, causing the metal to flow and fill the die cavities. The hammer is generally in contact with the workpiece on the scale of milliseconds. Depending on the size and complexity of the part, the hammer may be dropped multiple times in quick succession. Excess metal is squeezed out of the die cavities, forming what is referred to as flash. The flash cools more rapidly than the rest of the material; this cool metal is stronger than the metal in the die, so it helps prevent more flash from forming. This also forces the metal to completely fill the die cavity. After forging, the flash is removed.

In commercial impression-die forging, the workpiece is usually moved through a series of cavities in a die to get from an ingot to the final form. The first impression is used to distribute



the metal into the rough shape in accordance to the needs of later cavities; this impression is called an edging, fullering, or bending impression. The following cavities are called blocking cavities, in which the piece is working into a shape that more closely resembles the final product. These stages usually impart the workpiece with generous bends and large fillets. The final shape is forged in a final or finisher impression cavity. If there is only a short run of parts to be done, then it may be more economical for the die to lack a final impression cavity and instead machine the final features.

Impression-die forging has been improved in recent years through increased automation which includes induction heating, mechanical feeding, positioning and manipulation, and the direct heat treatment of parts after forging.

One variation of impression-die forging is called flashless forging, or true closed-die forging. In this type of forging, the die cavities are completely closed, which keeps the workpiece from forming flash. The major advantage to this process is that less metal is lost to flash. Flash can account for 20 to 45% of the starting material. The disadvantages of this process include additional cost due to a more complex die design and the need for better lubrication and workpiece placement.

There are other variations of part formation that integrate impression-die forging. One method incorporates casting a forging preform from liquid metal. The casting is removed after it has solidified, but while still hot. It is then finished in a single cavity die. The flash is trimmed, then the part is quench hardened. Another variation follows the same process as outlined above, except the preform is produced by the spraying deposition of metal droplets into shaped collectors (similar to the Osprey process).

Closed-die forging has a high initial cost due to the creation of dies and required design work to make working die cavities. However, it has low recurring costs for each part, thus forgings become more economical with more volume. This is one of the major reasons closed-die forgings are often used in the automotive and tool industry. Another reason forgings are common in these industrial sectors is that forgings generally have about a 20 percent higher strength-to-weight ratio compared to cast or machined parts of the same material.

## **Design Of Impression-Die Forgings And Tooling**

Forging dies are usually made of high-alloy or tool steel. Dies must be impact resistant, wear resistant, maintain strength at high temperatures, and have the ability to withstand cycles of rapid heating and cooling. In order to produce a better, more economical die the following rules should be followed:

The dies should part along a single, flat plane if at all possible. If not, the parting plane should follow the contour of the part.

The parting surface should be a plane through the center of the forging and not near an upper or lower edge.

Adequate draft should be provided; a good guideline is at least  $3^\circ$  for aluminum and  $5^\circ$  to  $7^\circ$  for steel.

Generous fillets and radii should be used.

Ribs should be low and wide.

The various sections should be balanced to avoid extreme difference in metal flow.

Full advantage should be taken of fiber flow lines.

Dimensional tolerances should not be closer than necessary.

The dimensional tolerances of a steel part produced using the impression-die forging method are outlined in the table below. The dimensions across the parting plane are affected by the closure of the dies, and are therefore dependent on die wear and the thickness of the final flash. Dimensions that are completely contained within a single die segment or half can be maintained at a significantly greater level of accuracy.

SSM is done at a temperature that puts the metal between its liquidus and solidus temperature. Ideally, the metal should be 30 to 65% solid. The metal must have a low viscosity to be usable, and to reach this low viscosity the material needs a globular primary surrounded by the liquid phase. The temperature range possible depends on the material and for aluminum alloys is 5–10  $^\circ\text{C}$ , but for narrow melting range copper alloys can be only several tenths of a degree.

Semi-solid casting is typically used for high-end castings. For aluminum alloys typical parts include engine suspension mounts, air manifold sensor harness, engine blocks and oil pump filter housing.

## **Processes**

There are a number of different techniques to produce semi-solid castings. For aluminum alloys the more common processes are thixocasting and rheocasting.

With magnesium alloys, the most common process is molding.

## **Thixo Casting**

Thixocasting utilizes a pre-cast billet with a non-dendritic microstructure that is normally produced by vigorously stirring the melt as the bar is being cast. Induction heating is normally used to re-heat the billets to the semi-solid temperature range, and die casting machines are used to inject the semi-solid material into hardened steel dies. Thixocasting is being performed commercially in North America, Europe and Asia. Thixocasting has the ability to produce extremely high quality components due to the product consistency that results from using pre-cast billet that is manufactured under the same ideal continuous processing conditions that are employed to make forging or rolling stock. The main disadvantage is that it is expensive due to the special billets that must be used. Other disadvantages include a limited number of alloys, and scrap cannot be directly reused.

## **Rheocasting**

Unlike thixocasting, which re-heats a billet, rheocasting develops the semi-solid slurry from the molten metal produced in a typical die casting furnace/machine. This is a big advantage over thixocasting because it results in less expensive feedstock, in the form of typical die casting alloys, and allows for direct recycling.

## **Thixomolding**

For magnesium alloys, thixomolding uses a machine similar to injection molding. In a single step process, room temperature magnesium alloy chips are fed into the back end of a heated barrel

through a volumetric feeder. The barrel is maintained under an argon atmosphere to prevent oxidation of the magnesium chips. A screw feeder located inside the barrel feeds the magnesium chips forward as they are heated into the semi-solid temperature range. The screw rotation provides the necessary shearing force to generate the globular structure needed for semi-solid casting. Once enough slurry has accumulated, the screw moves forward to inject the slurry into a steel die.

## **SIMA**

In the SIMA method the material is first heated to the SMM temperature. As it nears the solidus temperature the grains recrystallize to form a fine grain structure. After the solidus temperature is passed the grain boundaries melt to form the SSM microstructure. For this method to work the material should be extruded or cold rolled in the half-hard tempered state. This method is limited in size to bar diameters smaller than 37 mm (1.5 in); because of this only smaller parts can be cast.

## **Advantages and disadvantages**

The advantages of semi-solid casting are as follows:

Complex parts produced net shape

Porosity free

Excellent mechanical performance

Pressure tightness

Tight tolerances

Thin walls

Heat treatable (T4/T5/T6)

Due to the lower pressures and temperatures required to die cast semi-solid metal the die material does not need to be as exotic. Often graphite or softer stainless steels may be used. Even non-ferrous dies can be used for one time shots. Because of this the process can be applied to

rapid prototyping needs and mass production. This also allows for the casting of high melting point metals, such as tool steel and stellite, if a higher temperature die material is used. Other advantages include: easily automated, consistent, production rates are equal to or better than die casting rates, no air entrapment, low shrinkage rates, and a uniform microstructure.

The disadvantages to SSM are: high cost of raw material due to a low number of suppliers, higher die development costs, and operators require a higher level of training. SSM cannot cast as complex or thin of parts as high-pressure die casting, however in thicker walled castings SSM has less porosity.

## **CHAPTER - 11**

### **Centrifugal casting**

Centrifugal casting in silversmithing is a casting technique where a small mould is poured, then spun on the end of an arm. The centrifugal force thus generated encourages a successful pour.

Centrifugal force (from Latin *centrum*, meaning "center", and *fugere*, meaning "to flee") is the apparent force that draws a rotating body away from the center of rotation. It is caused by the inertia of the body as the body's path is continually redirected. In Newtonian mechanics, the term centrifugal force is used to refer to one of two distinct concepts: an inertial force (also called a "fictitious" force) observed in a non-inertial reference frame, and a reaction force corresponding to a centripetal force.

The term is also sometimes used in Lagrangian mechanics to describe certain terms in the generalized force that depend on the choice of generalized coordinates.

The concept of centrifugal force is applied in rotating devices such as centrifuges, centrifugal pumps, centrifugal governors, centrifugal clutches, etc., as well as in centrifugal railways, planetary orbits, banked curves, etc. These devices and situations can be analyzed either in terms of the fictitious force in the rotating coordinate system of the motion relative to a center, or in

terms of the centripetal and reactive centrifugal forces seen from a non-rotating frame of reference; these different forces are equal in magnitude, but centrifugal and reactive centrifugal forces are opposite in direction to the centripetal force.

## **History Of Conceptions Of Centrifugal And Centripetal Forces**

The conception of centrifugal force has evolved since the time of Huygens, Newton, Leibniz, and Hooke who expressed early conceptions of it. Its modern conception as a fictitious force arising in a rotating reference frame evolved in the eighteenth and nineteenth centuries. Centrifugal force has also played a role in debates in classical mechanics about detection of absolute motion. Newton suggested two arguments to answer the question of whether absolute rotation can be detected: the rotating bucket argument, and the rotating spheres argument. According to Newton, in each scenario the centrifugal force would be observed in the object's local frame (the frame where the object is stationary) only if the frame were rotating with respect to absolute space. Nearly two centuries later, Mach's principle was proposed where, instead of absolute rotation, the motion of the distant stars relative to the local inertial frame gives rise through some (hypothetical) physical law to the centrifugal force and other inertia effects. Today's view is based upon the idea of an inertial frame of reference, which privileges observers for which the laws of physics take on their simplest form, and in particular, frames that do not use centrifugal forces in their equations of motion in order to describe motions correctly.

The analogy between centrifugal force (sometimes used to create artificial gravity) and gravitational forces led to the equivalence principle of general relativity.

## **Fictitious Centrifugal Force**

Centrifugal force is often confused with centripetal force. Centrifugal force is most commonly introduced as an outward force apparent in a rotating frame of reference. It is apparent (fictitious) in the sense that it is not part of an interaction but is a result of rotation — with no reaction-force counterpart. This type of force is associated with describing motion in a non-inertial reference frame, and referred to as a fictitious or inertial force (a description that must be understood as a technical usage of these words that means only that the force is not present in a stationary or inertial frame).

There are three contexts in which the concept of fictitious centrifugal force arises when describing motion using classical mechanics:

In the first context, the motion is described relative to a rotating reference frame about a fixed axis at the origin of the coordinate system. For observations made in the rotating frame, all objects appear to be under the influence of a radially outward force that is proportional to the distance from the axis of rotation and to the square of the rate of rotation (angular velocity) of the frame.

The second context is similar, and describes the motion using an accelerated local reference frame attached to a moving body, for example, the frame of passengers in a car as it rounds a corner. In this case, rotation is again involved, this time about the center of curvature of the path of the moving body. In both these contexts, the centrifugal force is zero when the rate of rotation of the reference frame is zero, independent of the motions of objects in the frame.

The third context arises in Lagrangian mechanics, and refers to a subset of generalized forces that often are not equivalent to the vector forces of Newtonian mechanics. The generalized forces are called "generalized centrifugal forces" in this context (the word generalized is sometimes forgotten). They are related to the square of the rate of change of generalized coordinates (for example, polar coordinates), used in the Lagrangian formulation of mechanics. This topic is explored in more detail below.

If objects are seen as moving from a rotating frame, this movement results in another fictitious force, the Coriolis force; and if the rate of rotation of the frame is changing, a third fictitious force, the Euler force is experienced. Together, these three fictitious forces are necessary for the formulation of correct equations of motion in a rotating reference frame.

## **Reactive Centrifugal Force**

A reactive centrifugal force is the reaction force to a centripetal force. A mass undergoing curved motion, such as circular motion, constantly accelerates toward the axis of rotation. This centripetal acceleration is provided by a centripetal force, which is exerted on the mass by some other object. In accordance with Newton's third law of motion, the mass exerts an equal and opposite force on the object. This is the reactive centrifugal force. It is directed away from the

center of rotation, and is exerted by the rotating mass on the object that originates the centripetal acceleration.

This conception of centrifugal force is very different from the fictitious force. As they both are given the same name, they may be easily conflated. Whereas the 'fictitious force' acts on the body moving in a circular path, the 'reactive force' is exerted by the body moving in a circular path onto some other object. The former is useful in analyzing the motion of the body in a rotating reference frame; the latter is useful for finding forces on other objects, in an inertial frame.

This reaction force is sometimes described as a centrifugal inertial reaction, that is, a force that is centrifugally directed, which is a reactive force equal and opposite to the centripetal force that is curving the path of the mass.

The concept of the reactive centrifugal force is sometimes used in mechanics and engineering. It is sometimes referred to as just centrifugal force rather than as reactive centrifugal force.

### **Process of Centrifugal casting**

Centrifugal casting, or centrifuging, is used as a means of casting small, detailed parts or jewelry. An articulated arm is free to spin around a vertical axle, which is driven by an electric motor or a spring. The entire mechanism is enclosed in a tub or drum to contain hot metal should the mold break or an excess of metal be used. Single use molds are prepared using the lost wax method. A small amount of metal in a crucible (a sort of ceramic pan) next to the mold is heated with a torch. When the metal is molten the arm is released, forcing (by centrifugal force) the metal into the mold. The high forces imposed on the metal overcome the viscosity, resulting in a finely detailed workpiece. A similar advantage may be obtained by vacuum casting or pressure casting.

For industrial casting of small parts using poured hot metal, a disk shaped mold is contained within a rotating drum, and molten metal is poured into the center.



## **Glass**

The technique is known in the glass industry as "spinning". The centrifugal force pushes the molten glass against the mold wall, where it solidifies. This cooling process takes anywhere between 16 to 72 hours depending on the impurities or volume of material. Typical products made using this process are television picture tubes and missile nose cones.

The term is also applied to the fabrication of large telescope mirrors, where the natural curve followed by the molten glass greatly reduces the amount of grinding required. Rather than being cast by pouring glass into a mold an entire turntable containing the peripheral mold and the back pattern (a honeycomb pattern to lighten the finished product) is contained within a furnace and charged with the glass material used. The assembly is then heated while spun at slow speed until the glass is liquid, then gradually cooled over a period of months.

## **Applications**

Centrifugal casting is commonly used to shape glass into spherical objects such as marbles.

## **Machinery**

Many machines are available which can perform centrifugal casting, and they are relatively simple to construct. All that is required is an arm which rotates with an adequate amount of centrifugal force, a container on the end of said arm to hold both a mold and the material to be cast into the mold.

**Spin casting**, also known as centrifugal rubber mold casting (CRMC), is a method of utilizing centrifugal force to produce castings from a rubber mold. Typically, a disc-shaped mold is spun along its central axis at a set speed. The casting material, usually molten metal or liquid thermoset plastic is then poured in through an opening at the top-center of the mold. The filled mold then continues to spin as the metal solidifies or the thermoset plastic sets.

The two defining characteristics of spin casting are semi-permanent (non-expendable) rubber molds and the use of centrifugal force. These make the process relatively unique compared to

machined die-based and expendable mold casting methods. These qualities also encourage operators to use casting materials specially formulated for low melting points and viscosities. Most spin casting is done with pewter and zinc alloys or thermoset plastics.

## **Silicone molds**

The spin casting process typically uses vulcanized silicone or organic rubber as the mold-making substrate. Vulcanization is an integral step that occurs halfway through the mold-making process. Prior to vulcanization, the mold rubber is a soft and malleable solid-like fluid, in many ways very similar to Silly Putty. Because of the clay-like nature at this stage, the mold is easily cut or shaped to accommodate irregular models. Vulcanization serves two purposes: establishing the negative space inside the mold as well as hardening the rubber so it will remain strong and rigid during casting.

After vulcanization, before it is usable, the mold must undergo gating and venting. This involves carving channels to ensure proper air and material flow during the casting process. Gating and venting is typically done by hand using a sharp knife or scalpel and varies in time depending upon the complexity of the mold. The final product is a cured rubber mold which can withstand anywhere from hundreds to over a thousand casting cycles before it needs replacement.

## **Casting Material**

Generally, the casting materials used for competing processes like metal die casting and injection molding are similar, but not suitable for spin casting. For example, a typical zinc die-casting alloy such as zamak 3 can be used but will solidify too rapidly from a molten state when cast with centrifugal force. This typically results in incomplete filling of the mold as well as a rough, porous finish, called orange peel. Zamak 2, of a slightly different composition, was originally developed as a gravity-cast alloy with greater finished strength but was found to work well with spin-casting. Its extra copper content encourages the eutectic behaviour and gives a lower freezing point. It has become known as 'Kirksite' and has given rise to a range of dedicated spin-casting alloys, some with additional components such as magnesium, to control the surface finish.

To ensure replicable casting cycles of accurate reproductions with a high quality finish, the spin casting process requires casting materials with the following qualities, for the following reasons:

Low temperature operation - Spin casting is a low temperature process, as overexposure to high temperatures causes the rubber mold to degrade. Depending on the actual compound, the mold may become overly soft or hard while forming cracks and chips.

Slow solidification and low viscosity - Uniform and unrestricted flow of the casting material has a substantial effect on the quality and finish of the final items.

## **Plastic**

Aside from the aforementioned metal alloys, thermoset resins and plastics work well with spin casting as they can be introduced as liquids and will set or solidify while the mold spins. In general, spin casting encourages the use of casting materials that are liquid upon introduction to the mold and solidify at a slow, uniform rate during the spin cycle.

## **Spin Caster**

During the casting process, the finished mold spins along its central axis for anywhere from 30 seconds to several minutes depending upon the chosen casting material. Internally a spin casting machine or spin caster consists of a motor and pressure clamping system which holds and positions the mold properly while it spins at a steady rate. These components are placed inside of a machine body which shields against flashing of molten metal or liquid plastic that is inadvertently ejected from the mold during the spinning process. Without the proper containment, hot melted flashing can be a serious hazard to the machine operator and anyone else nearby.

Commercial spin casting machines are available in two different types, front-loading and top-loading. Due to the weight and bulkiness of spin casting molds, front loading machines tend to offer several advantages regarding ease of use and time savings. Rubber molds can become quite heavy, especially at larger diameters and when casting metal. Because loading and unloading the caster is performed by hand, it is easiest and less fatiguing to manipulate the mold at waist level in one fluid motion as allowed by a front-loading spin caster. This is especially important when

spin casting for production purposes where one is trying to maximize the number of complete casting cycles per hour.

Top loading machines tend to be cheaper and theoretically have less of a restriction on maximum mold thickness.

## **Vulcanizer**

As mentioned previously, vulcanization is a necessary step to prepare the uncured silicone mold for spin casting production. Under controlled heat and pressure the silicone slowly cures to a heat resistant, flexible, permanent mold. The vulcanizing press or vulcanizer uniformly compresses the mold while exposing it to high temperature over a period of several hours. The vulcanizer consists of a pair of parallel heated platens mounted on a hydraulic press. Smaller or home-made vulcanizers may compress the mold via screws or a heavy duty clamp instead of hydraulic pressure. Some spin casting operations choose to forgo running their own vulcanizer and instead contract out their mold production.

## **Melting Furnace**

A melting furnace is necessary only when spin casting with metal. Understandably the metal must be in a molten state prior to introduction into the mold. However, it is necessary for a spin casting furnace to have a temperature controller as there is an approximate range that works best for each metal. For example a particular zinc alloy is typically cast between 775-800 °F, whereas it actually melts much lower around 500 °F. If the metal is introduced to the mold at a higher temperature (in this case, above 800 °F), it will start to wear the silicone down prematurely, greatly shortening the mold life. If the metal is introduced at significantly lower temperatures (below 775 °F), its solidification time will similarly be shortened resulting in incomplete or low quality castings. Therefore, spin casting with metal requires not only a furnace with fine temperature control, but knowledge of at what range to cast.

## CHAPTER - 12

### Continuous Casting

Continuous casting, also called strand casting, is the process whereby molten metal is solidified into a "semifinished" billet, bloom, or slab for subsequent rolling in the finishing mills. Prior to the introduction of continuous casting in the 1950s, steel was poured into stationary molds to form ingots. Since then, "continuous casting" has evolved to achieve improved yield, quality, productivity and cost efficiency. It allows lower-cost production of metal sections with better quality, due to the inherently lower costs of continuous, standardised production of a product, as well as providing increased control over the process through automation. This process is used most frequently to cast steel (in terms of tonnage cast). Aluminium and copper are also continuously cast.

Sir Henry Bessemer, of Bessemer converter fame, received a patent in 1857 for casting metal between two contra-rotating rollers. The basic outline of this system has recently been implemented today in the casting of steel strip.

### Equipment And Process

Molten metal is tapped into the ladle from furnaces. After undergoing any ladle treatments, such as alloying and degassing, and arriving at the correct temperature, the ladle is transported to the top of the casting machine. Usually the ladle sits in a slot on a rotating turret at the casting machine. One ladle is in the 'on-cast' position (feeding the casting machine) while the other is made ready in the 'off-cast' position, and is switched to the casting position when the first ladle is empty.

From the ladle, the hot metal is transferred via a refractory shroud (pipe) to a holding bath called a tundish. The tundish allows a reservoir of metal to feed the casting machine while ladles are switched, thus acting as a buffer of hot metal, as well as smoothing out flow, regulating metal feed to the molds and cleaning the metal (see below).

Metal is drained from the tundish through another shroud into the top of an open-base copper mold. The depth of the mold can range from 0.5 to 2 metres (20 to 79 in), depending on the casting speed and section size. The mold is water-cooled to solidify the hot metal directly in

contact with it; this is the primary cooling process. It also oscillates vertically (or in a near vertical curved path) to prevent the metal sticking to the mold walls. A lubricant can also be added to the metal in the mold to prevent sticking, and to trap any slag particles—including oxide particles or scale—that may be present in the metal and bring them to the top of the pool to form a floating layer of slag. Often, the shroud is set so the hot metal exits it below the surface of the slag layer in the mold and is thus called a submerged entry nozzle (SEN). In some cases, shrouds may not be used between tundish and mold; in this case, interchangeable metering nozzles in the base of the tundish direct the metal into the moulds. Some continuous casting layouts feed several molds from the same tundish.

In the mold, a thin shell of metal next to the mold walls solidifies before the middle section, now called a strand, exits the base of the mold into a spray chamber. The bulk of metal within the walls of the strand is still molten. The strand is immediately supported by closely spaced, water-cooled rollers which support the walls of the strand against the ferrostatic pressure (compare hydrostatic pressure) of the still-solidifying liquid within the strand. To increase the rate of solidification, the strand is sprayed with large amounts of water as it passes through the spray-chamber; this is the secondary cooling process. Final solidification of the strand may take place after the strand has exited the spray-chamber.

It is here that the design of continuous casting machines may vary. This describes a 'curved apron' casting machine; vertical configurations are also used. In a curved apron casting machine, the strand exits the mold vertically (or on a near vertical curved path) and as it travels through the spray-chamber, the rollers gradually curve the strand towards the horizontal. In a vertical casting machine, the strand stays vertical as it passes through the spray-chamber. Molds in a curved apron casting machine can be straight or curved, depending on the basic design of the machine.

In a true horizontal casting machine, the mold axis is horizontal and the flow of steel is horizontal from liquid to thin shell to solid (no bending). In this type of machine, either strand or mold oscillation is used to prevent sticking in the mold.

After exiting the spray-chamber, the strand passes through straightening rolls (if cast on other than a vertical machine) and withdrawal rolls. There may be a hot rolling stand after withdrawal

to take advantage of the metal's hot condition to pre-shape the final strand. Finally, the strand is cut into predetermined lengths by mechanical shears or by travelling oxyacetylene torches, is marked for identification, and is taken either to a stockpile or to the next forming process.

In many cases the strand may continue through additional rollers and other mechanisms which may flatten, roll or extrude the metal into its final shape.

### **Casting Machines For Aluminium And Copper**

Aluminium and copper can be cast horizontally and can be more easily cast into near net shape, especially strip, due to their lower melting temperatures.

### **Range Of Continuously Cast Sections**

Casting machines are designated to be billet, bloom or slab casters.

Slab casters tend to cast sections that are much wider than thick:

Conventional slabs lie in the range 100–1600 mm wide by 180–250 mm thick and up to 12 m long with conventional casting speeds of up to 1.4 m/minute; however slab widths and casting speeds are currently increasing.

Wider slabs are available up to 3250×150 mm, for example at Nanjing Iron & Steel in China.

Thick slabs are available up to 2200×450 mm, for example at Dillinger Hütte in Dillingen, Germany.

Thin slabs: 1680×50 mm

Conventional bloom casters cast sections above 200×200 mm e.g. the Aldwarke Bloom caster in Rotherham, UK, casts sections of 560×400 mm. The bloom length can vary from 4 to 10 m

Billet casters cast smaller section sizes, such as below 200 mm square, with lengths up to 12 m long. Cast speeds can reach up to 4 m/minute.

Rounds: either 500 mm or 140 mm in diameter

Conventional beam blanks: look similar to I-beams in cross-section; 1048×450 mm or 438×381 mm overall

Near net shape beam blanks: 850×250 mm overall

Strip: 2–5 mm thick by 760–1330 mm wide

### **Startup, Control Of The Process And Problems**

Starting a continuous casting machine involves placing a dummy bar (essentially a curved metal beam) up through the spray chamber to close off the base of the mould. Metal is poured into the mould and withdrawn with the dummy bar once it solidifies. It is extremely important that the metal supply afterwards be guaranteed to avoid unnecessary shutdowns and restarts, known as 'turnarounds'. Each time the caster stops and restarts, a new tundish is required, as any uncast metal in the tundish cannot be drained and instead freezes into a 'skull'. Avoiding turnarounds requires the meltshop, including ladle furnaces (if any) to keep tight control on the temperature of the metal, which can vary dramatically with alloying additions, slag cover and deslagging, and the preheating of the ladle before it accepts metal, among other parameters. However, the cast rate may be lowered by reducing the amount of metal in the tundish (although this can increase wear on the tundish), or if the caster has multiple strands, one or more strands may be shut down to accommodate upstream delays. Turnarounds may be scheduled into a production sequence if the tundish temperature becomes too high after a certain number of heats.

Many continuous casting operations are now fully computer-controlled. Several electromagnetic and thermal sensors in the ladle shroud, tundish and mould sense the metal level or weight, flow rate and temperature of the hot metal, and the programmable logic controller (PLC) can set the rate of strand withdrawal via speed control of the withdrawal rolls. The flow of metal into the moulds can be controlled via two methods:

By slide gates or stopper rods at the top of the mould shrouds

If the metal is open-poured, then the metal flow into the moulds is controlled solely by the internal diameter of the metering nozzles. These nozzles are usually interchangeable.



Overall casting speed can be adjusted by altering the amount of metal in the tundish, via the ladle slide gate. The PLC can also set the mould oscillation rate and the rate of mould powder feed, as well as the spray water flow. Computer control also allows vital casting data to be repeated to other manufacturing centres (particularly the steelmaking furnaces), allowing their work rates to be adjusted to avoid 'overflow' or 'underrun' of product.

While the large amount of automation helps produce castings with no shrinkage and little segregation, continuous casting is of no use if the metal is not clean beforehand, or becomes 'dirty' during the casting process. One of the main methods through which hot metal may become dirty is by oxidation, which occurs rapidly at molten metal temperatures (up to 1700 °C); inclusions of gas, slag or undissolved alloys may also be present. To prevent oxidation, the metal is isolated from the atmosphere as much as possible. To achieve this, exposed metal surfaces are covered – by the shrouds, or in the case of the ladle, tundish and mould, by synthetic slag. In the tundish, any inclusions – gas bubbles, other slag or oxides, or undissolved alloys – may also be trapped in the slag layer.

A major problem that may occur in continuous casting is breakout. This is when the thin shell of the strand breaks, allowing the still-molten metal inside the strand to spill out and foul the machine, requiring a turnaround. Often, breakout is due to too high a withdrawal rate, as the shell has not had the time to solidify to the required thickness, or the metal is too hot, which means that final solidification takes place well below the straightening rolls and the strand breaks due to stresses applied during straightening. A breakout can also occur if solidifying steel sticks to the mould surface, causing a tear in the shell of the strand. If the incoming metal is overheated, it is preferable to stop the caster than to risk a breakout. Additionally, lead contamination of the metal (caused by counterweights or lead-acid batteries in the initial steel charge) can form a thin film between the mould wall and the steel, inhibiting heat removal and shell growth and increasing the risk of breakouts.

Another problem that may occur is a carbon boil – oxygen dissolved in the steel reacts with also-present carbon to generate bubbles of carbon monoxide. As the term boil suggests, this reaction is extremely fast and violent, generating large amounts of hot gas, and is especially dangerous if it occurs in the confined spaces of a casting machine. Oxygen can be removed through the addition of silicon or aluminium to the steel, which reacts to form silicon oxide (silica) or

aluminium oxide (alumina). However, too much alumina in the steel will clog the casting nozzles and cause the steel to 'choke off'.

Computational fluid dynamics and other fluid flow techniques are being used extensively in the design of new continuous casting operations, especially in the tundish, to ensure that inclusions and turbulence are removed from the hot metal, yet ensure that all the metal reaches the mould before it cools too much. Slight adjustments to the flow conditions within the tundish or the mould can mean the difference between high and low rejection rates of the product.

### **Starter Bar**

The starter bar, also called a dummy bar, has a free end portion which is flexible for storage and a substantially rigid portion at the end which plugs the mold. The starter bar is constructed in discrete blocks secured to one side of a planar spine provided in segments and arranged end to end. Adjustable spacers in the form of tapered blocks are disposed between the blocks of the bar to allow the starter bar to be self-supporting in a curved configuration corresponding to the casting path. A more flexible spine in the end portion of the starter bar allows the starter bar to be curved to a tighter radius than that of the casting path while the blocks fan out in an unsupported configuration. A storage ramp is provided to support the flexible end in the stored position. Before a cast is started, the starter bars are fed through the caster (in reverse direction of casting) using hydraulic actuators. Once fed all the way to the bottom of the mold, the process of packing the mold can continue to ensure a smooth start up.

### **Direct Strip Casting**

Direct strip casting is a continuous casting process for producing metallic sheet directly from the molten state that minimises the need for substantial secondary processing.

### **Twin-Belt Continuous Casting**

Twin-belt continuous casting is a continuous casting process that produces high volume continuous metal bar or strip of constant rectangular cross section. Twin-belt continuous casting employs a moving mold consisting of parallel carbon-steel belts held in tension as top and

bottom casting surfaces. Chains of rectangular steel or copper blocks moving with the belts and spaced according to the desired cast width form the sides of the mold.

Molten metal is introduced into the twin-belt continuous casting machine from a tundish through a nozzle placed between the casting belts. The metal is cooled by direct contact with the belts which are in turn cooled by high pressure recirculating water. Various coatings can be applied to the belt casting surfaces to provide required mold interface characteristics and prevent adhesion.

The cast metal from the twin-belt continuous casting machine is synchronized with, and directly fed into, a hot rolling mill. Combining the casting and rolling operations can result in significant energy and cost savings over other casting processes which incorporate intermediate cast and reheat steps.

Metals Cast on Twin-Belt Continuous Casting Machines: Copper (Bar, Strip, Anode), Aluminum(Strip), Zinc (Strip), Lead (Strip)

Production rates and speeds: Twin-belt continuous casting rates range up to 60 tons per hour at speeds up to 14 meters per minute.

Twin-belt continuous casting is a near net shape casting process, which significantly reduces the need for secondary rolling or forming operations. For example, when casting copper anode plate the cast slab is not rolled but rather sheared directly into distinct anode plates.

The cooling belts are typically made of low carbon steel and are held under tension within the casting machine to ensure flatness and accuracy. As a "cold" belt enters the mold region, it is heated in the cast zone and is subject to powerful forces caused by thermal expansion. When casting wide strip, these forces must be controlled to eliminate buckling and reduce thermal distortion of the belt at the mold entrance. These forces can be controlled by preheating the belts before mold entry, or by magnetically stabilizing them once they have entered the mold.

Belt Preheating: For wide strip casting, a belt preheating system can be used to bring the belt up to 150°C or higher immediately prior to entering the casting mold, reducing the effects of cold framing. Induction heating coils can be used across the width to preheat each belt. In addition to preventing thermal distortion, the high preheat temperature serves to eliminate any moisture present on the belt surface.

**Magnetic Stabilization:** When casting wide strip, the tendency of localized thermal distortion can be resisted by the use of high-strength, magnetic belt back-up support rolls within the mold region. The moving belt is held against the support rolls by magnetized rotating fins maintaining the belt in a flat plane.

Within the twin-belt continuous casting machine, molten metal progressively solidifies on the mold surfaces as it moves thru the mold region, with a sump of molten metal present between the solidifying outer surfaces. Belt coatings, texture, and gas layer modifications are used to fine tune the heat transfer rate from the cast metal to the belt. Full thickness solidification can occur as early as 30% of the way through the mold for thin strip, or up to 2 m beyond the mold exit for large bar where exit water spray cooling and roller support are required.

**Closed Pool Feeding:** When casting certain metals such as aluminum, a fully closed pool “injection” metal feeding system can be employed. Here, the metal is introduced under slight pressure into the closed mold cavity. Metal flow is controlled by maintaining a preset level in the tundish. The feed snout, or nozzle, is typically made from a ceramic material which is thermally stable and permeable to gases being released from the flowing metal.

**Open Pool Feeding:** When casting other metals, such as copper, zinc and lead, an open pool feeding system is often used. In this case, the upper belt pulley is offset downstream from the bottom pulley. Metal flows through an open trough or tundish into a standing pool of molten metal formed at the convergence of the belts. Shrouding gases may be employed to protect against oxidation.

**Mold Tapering:** The twin-belt casting machine differs from other moving mold casting machines in that all four mold surfaces are independent. This allows the mold surfaces to be tapered to remain in contact with the cast product as it shrinks. The high velocity cooling water, which is continuously applied to the backside of the belt, impinges on the belt and creates a force on the belt. This force acts to press the belt against the surface of the strip or slab as it shrinks, keeping the belt in close contact with the cast product throughout the mold. Each side of the mold is formed by an endless chain of dam blocks, which are held against the cast strip by adjustable spring-loaded guides.

Molten Metal Level Control: To accommodate high casting speeds and maintain as high a pool level as possible, non-contact electromagnetic metal level indicators can be used to sense the pool level in the casting machine.

Aluminum or copper strip casting: Commercial twin-belt continuous strip casting machines are capable of producing as-cast dimensions from 10-35 mm thick, and up to 2035 mm wide. After being directly fed into a hot rolling mill, the as-cast strip is typically rolled down to 1-3 mm thickness strip.

Copper bar casting: As-cast dimensions range from 35-75 mm thick, and from 50-150 mm wide. After being directly fed into a hot rolling mill, the as-cast bar is typically rolled into 8 mm diameter rod to be used for wire drawing.

Copper anode casting: Special dam blocks which contain anode lug molds and a traveling hydraulic shear are added to the twin-belt casting machine to continuously cast net shape copper anodes. Anode width of approximately 1 meter (excluding lugs) and thicknesses from 16 mm to 45 mm. The primary advantage of this process is uniformity of the as-cast anode in terms of size and surface quality. Anodes cast using this process do not require additional preparation after casting.

Mold Length: The mold length ranges from approximately 2000 mm for strip casting machines and up to 3700 mm for copper bar casting machines.

## **Bibliography**

- Blair, Malcolm; Stevens, Thomas L. (1995), Steel castings handbook (6th ed.), ASM International, ISBN 978-0-87170-556-3.
- Degarmo, E. Paul; Black, J T.; Kohser, Ronald A. (2003), Materials and Processes in Manufacturing (9th ed.), Wiley, ISBN 0-471-65653-4.
- Kalpakjian, Serop; Schmid, Steven (2006), Manufacturing Engineering and Technology (5th ed.), Pearson, ISBN 0-13-148965-8.
- Kissell, J. Randolph; Ferry, Robert L. (2002), Aluminum structures: a guide to their specifications and design (2nd ed.), John Wiley and Sons, ISBN 978-0-471-01965-7.

- Schleg, Frederick P.; Kohloff, Frederick H.; Sylvia, J. Gerin; American Foundry Society (2003), Technology of Metalcasting, American Foundry Society, ISBN 978-0-87433-257-5.
- Stefanescu, Doru Michael (2008), Science and Engineering of Casting Solidification (2nd ed.), Springer, ISBN 978-0-387-74609-8.
- Ravi, B (2010), Metal Casting: Computer-aided Design and Analysis (1st ed.), PHI, ISBN 81-203-2726-8.
- Degarmo, E. Paul; Black, J T.; Kohser, Ronald A. (2003), Materials and Processes in Manufacturing (9th ed.), Wiley, ISBN 0-471-65653-4.
- Campbell, John (2003), Casting (2nd ed.), Butterworth-Heinemann, ISBN 0-7506-4790-6.
- Ravi, B. (2005), Metal Casting: Computer-Aided Design and Analysis (1st ed.), PHI, ISBN 81-203-2726-8.
- Degarmo, E. Paul; Black, J T.; Kohser, Ronald A. (2003), Materials and Processes in Manufacturing (9th ed.), Wiley, ISBN 0-471-65653-4.
- Kalpakjian, Serope; Schmid, Steven (2006), Manufacturing Engineering and Technology (5th ed.), Pearson, ISBN 0-13-148965-8.
- Todd, Robert H.; Dell K. Allen and Leo Alting (1994), Manufacturing Processes Reference Guide, Industrial Press Inc, ISBN 0-8311-3049-0
- Degarmo, E. Paul; Black, J T.; Kohser, Ronald A. (2003). Materials and Processes in Manufacturing (9th ed.). Wiley. ISBN 0-471-65653-4.
- Todd, Robert H.; Dell K. Allen and Leo Alting (1994). Manufacturing Processes Reference Guide. Industrial Press Inc. ISBN 0-8311-3049-0.
- American Society for Metals; ASM International Handbook Committee; ASM International Alloy Phase Diagram Committee (1990),ASM Handbook: Casting 15 (10th ed.), ASM International, ISBN 978-0-87170-021-6.

- Degarmo, E. Paul; Black, J T.; Kohser, Ronald A. (2003), Materials and Processes in Manufacturing (9th ed.), Wiley, ISBN 0-471-65653-4.
- Sias, Fred R. (2006), Lost-wax Casting: Old, New, and Inexpensive Methods (illustrated ed.), Woodsmere Press, ISBN 978-0-9679600-0-5.
- American Society for Metals; Stefanescu, D M; ASM International Handbook Committee; ASM International Alloy Phase Diagram Committee (1991), ASM Handbook 15 (10th ed.), ASM International, ISBN 978-0-87170-021-6.
- Degarmo, E. Paul; Black, J T.; Kohser, Ronald A. (2003), Materials and Processes in Manufacturing (9th ed.), Wiley, ISBN 0-471-65653-4.
- Totten, George E.; Funatani, Kiyoshi; Xie, Lin (2004), Handbook of metallurgical process design (illustrated ed.), CRC Press, ISBN 978-0-8247-4106-8.

“The lesson content has been compiled from various sources in public domain including but not limited to the internet for the convenience of the users. The university has no proprietary right on the same.”



9, Km Milestone, NH-65, Kaithal - 136027, Haryana  
Website: [www.niilmuniversity.in](http://www.niilmuniversity.in)